

July  
1940

*Radio*

# SERVICE DEALER

SOUNDMAN \* JOBBER

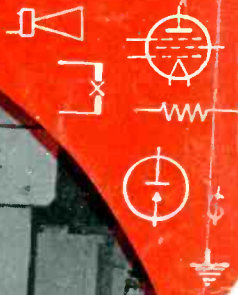

Price  
20¢

**\*FP** (*Fabricated Plate*)

TRADE MARK REG. U. S. PAT. OFF.

# CONDENSERS

made by

**P. R. MALLORY & CO., Inc.**  
**MALLORY..**

With over 5,000,000 FP Condensers in use as original equipment . . . the field returns on 1,000,000 . . . purchased by representative manufacturers were accurately checked. The answer has made radio history. Out of 1,000,000 FP Condensers made by Mallory only 512 were returned as defective. That's just 5/100th of 1%!

As a radio service engineer, this is news that you can't afford to overlook. FP Replacement Condensers, made by Mallory, are identical in every specification and quality to those used in original equipment—and made by Mallory. They offer you a replacement opportunity that to all practical purposes eliminates the possibility of troublesome call-backs.

But there's this to remember. The outstanding success of FP Condensers has caused them to be imitated. But the imitation is only skin deep. So don't make the mistake of expecting Fabricated Plate performance from a condenser that merely *looks* like a genuine FP Condenser.

In the sets you service . . . you'll recognize genuine FP Condensers by the name MALLORY or by the figure (1) enclosed in a circle.

For all your other condenser replacement needs Mallory's full line offers similar opportunities for full profit and complete customer satisfaction. Get details on the entire line from your Mallory Distributor today.

**P. R. MALLORY & CO., Inc.**  
INDIANAPOLIS INDIANA  
Cable Address—PELMALLO

**Put the Come-back Odds  
2000 to 1  
in Your  
Favor**

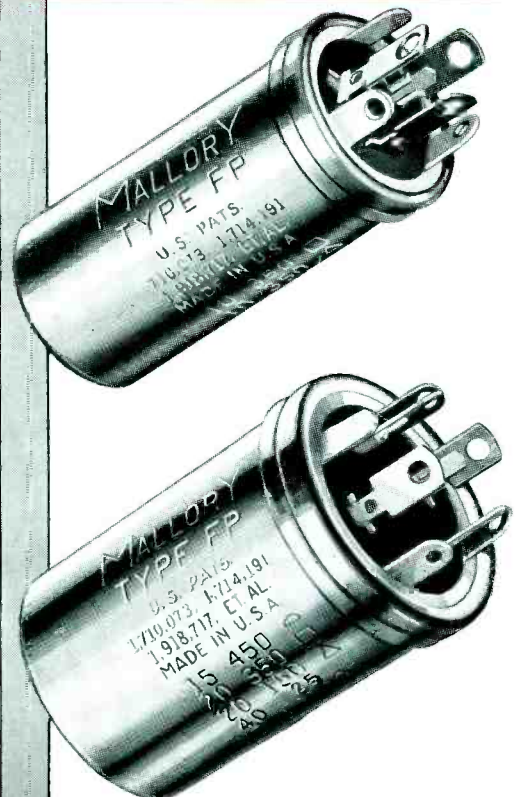

*\*Not etched construction*

Use

**P. R. MALLORY & CO. Inc.**  
**MALLORY**  
APPROVED  
PRECISION PRODUCTS

*Include*

VIBRATORS • VIBRAPACKS • CONDENSERS • VOLUME  
CONTROLS • ROTARY SWITCHES • SINGLE AND  
MULTIPLE PUSH BUTTON SWITCHES • RESISTORS  
RADIO HARDWARE

July 40

*Radio*

# SERVICE-DEALER

## SOUNDMAN AND JOBBER

### Ad Index

<b>Bank's Mfg. Co.</b> . . . . .	16
Televox Intercomm Systems	
<b>Centralab</b> . . . . .	3rd Cover
Sound Projection Controls	
<b>Clarostat Mfg. Co., Inc.</b> . . . . .	26
Controls, Service Manual	
<b>Jackson Electrical Inst. Co., The</b> . . . . .	27
Dynamic Tube Testers	
<b>Mallory &amp; Co., P. R.</b> . . . . .	2nd Cover
Fabricated Plate Condensers	
<b>National Union Radio Corp.</b> . . . . .	4th Cover
Condenser Assortment in Steel Cabinet	
<b>Racon Electric Co.</b> . . . . .	2
Horn and Cone Speakers	
<b>Raytheon Production Corp.</b> . . . . .	15
Transmitting & Receiving Tubes	
<b>Radio Servicemen of America</b> . . . . .	28
Membership	
<b>Supreme Instruments Corp.</b> . . . . .	25
Model 549 Electronic Voltmeter	
<b>Triplett Electrical Inst. Co., The</b> . . . . .	26
Model 1183 Combination Tester	
<b>Universal Microphone Co., Ltd.</b> . . . . .	27
New Universal Catalog	
<b>Ward Products Corp., The</b> . . . . .	27
Flex-Angle Antennas	

### Contents

<b>Transients (Editorial):</b>	
The Old Tinsel . . . . .	3
Electronic Knotholes . . . . .	3
Off The Record . . . . .	3
Jobbers' Job . . . . .	3
Phono Servicing . . . . .	4
The Show In Review . . . . .	6
Serviceman's Diary . . . . .	7
By J. P. Hollister	
Horace (Cartoon Strip) . . . . .	7
Electronic Gadgeteering In Fence Controllers . . . . .	8
<b>Circuit Court:</b>	
G. E. Model HM-136 Delayed AVC . . . . .	10
Crosley Model 549 Automatic Tube Feed . . . . .	10
<b>Technical Service Portfolio:</b>	
Section III—	
Data On Condensers . . . . .	11
<b>Shop Notes:</b>	
Fada P58, PL58 Tube Substitution . . . . .	17
Stromberg-Carlson 400 Series Dial Pointer . . . . .	17
Stromberg-Carlson FM-AM Antenna Connections . . . . .	17
Stromberg-Carlson No. 470 Phono Compensation . . . . .	17
Zenith 1940 Line, General Notes . . . . .	17
Trade Showings . . . . .	18
<b>Show Literature For The Serviceman:</b>	
Catalogs—Bulletins . . . . .	23
Servicing Aids . . . . .	24

### Cover Photo



★ Introduced at the June Trade Show was this battery-operated amplifier and microphone which together make a portable paging system. It was made for show manager Ken Hathaway. See article on page 6.

Published Monthly by

**COWAN PUBLISHING CORP.**

11 WEST 42nd ST., NEW YORK, N. Y.  
Telephone: CHickering 4-3278-9

**M. L. MUHLEMAN, EDITOR**  
**S. R. COWAN, ADV. MANAGER**

Subscription rate, \$2.00 a year in U. S. and Canada; single copies, 20 cents. In foreign countries, \$4.00 a year. Editorial and advertising offices, 11 West 42nd St., New York, N. Y.

VOL. 1 No. 4 ★ JULY, 1940

Copyright, 1940, Cowan Publishing Corp.

**RACON**  
KING OF SOUND

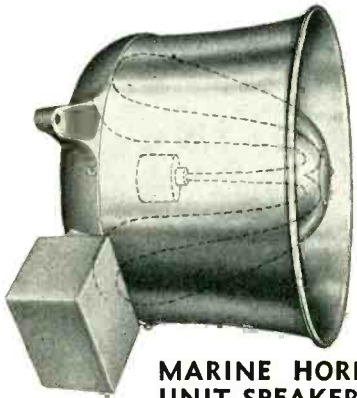

**MARINE HORN UNIT SPEAKERS**

Re-entrant type speakers using horn type units for marine and general P-A applications—may be used as loudspeaker or as a microphone. Miniature and regular sizes approved by the Bureau of Marine Inspection and Navigation, Department of Commerce, for marine work. In all sizes, miniature, midjet, regular and bull, handling from 5 to 50 watts.

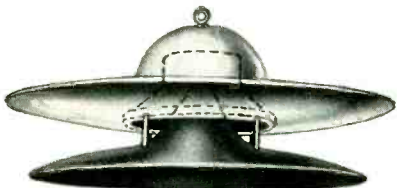

**RADIAL CONE SPEAKERS**

Types for high fidelity, giving even intensity sound projection over a circumference of 360° radially. Upper deflector made of heavy gauge aluminum, cone covering of steel, and lower deflector of RACON ACOUSTIC material storm-proofed for all weather conditions. Models for 5" — 6" — 10" — 12" cone speakers.



**RE-ENTRANT TRUMPETS**

A compact trumpet of the double re-entrant type. Occupies but a small space, nevertheless has a long air column enabling it to deliver highly concentrated sound of the greatest efficiency over long distances. Base and inside cone arm made of aluminum castings, outside bell of heavy gauge aluminum spinning, center section of RACON ACOUSTIC material to prevent resonant effects. Available in 6', 4½', 3½', and 3' air column units.

**Super Giant P. M. Horn Unit**

Operating capacity 12-15 watts, peak 25 watts. Other P.M. Units available, from "baby unit" of 5 watts to "bull unit" with an operating capacity of 50 watts. Efficiencies of the highest order obtainable with the finest magnetic material and steel utilized.



## RACON PRODUCTS are Preferred— Outperform and Outsell all others

Leading jobbers recommend and leading soundmen everywhere prefer and specify RACON PRODUCTS . . . not simply because Racon is the industry's pioneer and largest manufacturer of sound reproducing horns and speaker units. Experience has proven that RACON PRODUCTS are the most dependable, and efficient to use and are thus most profitable.

RACON horns, speakers and speaker units outperform all others because they are built to the highest standards of quality—each containing many exclusive and patented features which make them outstanding in comparison with any other brand. RACON engineering advances have caused emulators to bring out reproducing units which are somewhat similar in outward appearance but of course these units cannot compare with RACONS in quality, dependability and efficiency.

RACON outsells all others for many reasons. List prices and discounts are 'right'. Jobbers are protected and the RACON Guarantee is backed up by a reliable, well established manufacturer. More important, RACON units are easier to sell because they are known to be quality products and in the Sound Business quality is the only assurance to a profitable sale. Then again, there is a RACON Horn, Speaker, Baffle and Speaker Unit for every purpose . . . the most complete line available. Leading Jobbers in your territory will be happy to explain in detail all of the exclusive features incorporated in every RACON unit.

Illustrated here are several RACON PRODUCTS. Complete data and literature sent on request.

# RACON

## ELECTRIC CO.

52 East 19th St. New York, N. Y.



**Marine Cone Unit Speakers**

Re-entrant type speakers of the marine type using cone type driving units for indoor and outdoor applications. Bell made of heavy gauge aluminum, cone mounting made of aluminum casting, and center bullet of RACON ACOUSTIC material to prevent resonant effects. Material stormproofed for all weather conditions. Baby size for 2" or 3", miniature for 5", regular for 8", and giant for 12" speakers.

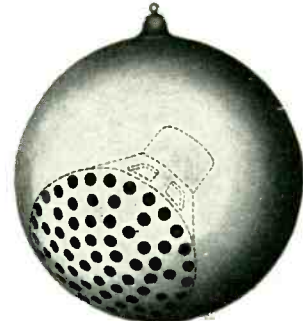

**BALL TYPE CONE SPEAKER**

A new type of ball speaker to be used where directional sound is required and where the standard type of cone projectors clash with the surrounding furnishings or architecture. Made of steel finished in silver with a hanging lamp fixture. Acts as an unlimited baffle giving low response down to 60 cycles and high response up to 10,000 cycles. Made in sizes to take 6"-8"-10" cone speakers.

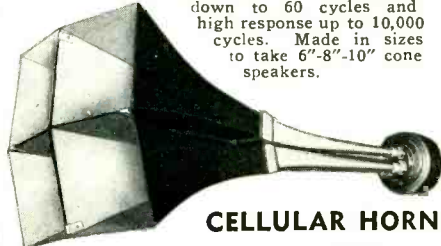

**CELLULAR HORNS**

For operation between 350 and 12,000 cycles with angular distribution of 60°. Uses a highly efficient P.M. Unit with a patented phase-cancellation compensating device, reproducing all frequencies without cancellation effects. Made only in blocs of 4 cells of RACON UNBREAKABLE MATERIAL.



**PAGING HORN**

A small, extremely efficient 2-foot trumpet speaker, for use where highly concentrated sound is required to override high noise levels, such as in factories, outdoors, etc. Uses a small, very efficient Permanent Magnet unit. Particularly adaptable for paging systems, hotel lobbies, trucks, etc. Horn made of RACON ACOUSTIC storm-proof material with a beaded edge around the bell. Cast aluminum tone arm. Unit covered with aluminum case. Bell diameter 12"; overall length 29".

# Transients

**THE OLD TINSEL . . .** A prospective customer, oozing confidence in the Watchdogs of Radio, phones a local serviceman, and the following conversation transpires:

*Customer:* My radio has developed a peculiar noise and I'd like to have it fixed. What do you suppose is wrong, and could you give me an idea as to how much it would cost to put it in shape?

*Serviceman:* Well, I don't know. What does the noise sound like?

*Customer:* Oh, something like 'garump', but it's not steady; it comes on and goes off.

*Serviceman:* Well, I can't tell much by that. Couldn't you be more specific? Maybe I could tell if you could be more specific.

*Customer:* I'm telling you, it sounds like 'garump'. Like a stone crusher, if you've ever heard one.

*Serviceman:* I couldn't tell anything by that. The noise could be due to any number of things. I'd have to look the set over before I could tell what was wrong and make an estimate.

*Customer:* Listen, you asked me what the noise sounded like and I told you. Now you say you can't tell anything from that. What did you ask me for anyway?

*Serviceman:* You can't expect me to diagnose the trouble over the phone, any more than a doctor can. That noise might be due to any number of things, and I couldn't tell until I tested the set.

*Customer:* It is a constant wonder to me how some men manage to stay in business. Never mind—I'll get someone else.

*Serviceman:* If you'd just let me . . . (the customer has hung up).

Our ruffled customer, with a chip on his shoulder, phones another local serviceman, and the following conversation transpires:

*Customer:* See here, my radio has developed a hell of a noise and I want it fixed, but I want to know what it's going to cost.

*Serviceman:* Is it a swishing noise?

*Customer:* No, it sounds more like 'garump'.

*Serviceman:* Is the 'garump' followed by a clucking noise? Because, if it is, it's unquestionably a case of second harmonics superimposed on the intermediate frequency.

*Customer:* No, I don't recall any clucking . . .

*Serviceman:* Well, you're fortunate,

then; that might well call for the replacement of the i-f transformer feeding the demodulator. But, tell me, is it as much of a 'garump' as it is a 'gwacking' noise. If it is a 'garump', then the oscillator is intermittent and is blocking the converter tube. On the other hand, if it is a 'gwacking' noise, the demodulator is not operating on the linear portion of its characteristic curve.

*Customer:* Well, it sounds like 'garump' to me, but I suppose it might be described as a 'gwacking' noise.

*Serviceman:* I know how it is—it's pretty difficult to describe by words all the various noises a radio can make when something is wrong. To this day, I can't do it.

*Customer:* But if you heard it yourself, I suppose you'd know what was wrong?

*Serviceman:* Oh, yes. That's our business. We get to know what the various noises mean in the way of trouble.

*Customer:* Well, call by for the set, will you? And let me know what it's going to cost.

*Serviceman:* Sure thing.

The moral of this is—don't make yourself out a sap. If you have to dress your conversation with a bit of tinsel in order to impress a customer, and to avoid making a diagnosis over the phone which may later get you in hot water, by all means use the tinsel and confuse the prospective client. He figures you're some sort of a wizard and therefore assumes that you can diagnose a receiver ailment by listening to his word description of the symptoms. Don't destroy that confidence. Many doctors have made the same error, much to their sorrow. By all means, never let a customer put you on the defensive. Where necessary, talk above his head, and he'll soon leave matters in your hands.

★

**ELECTRONIC KNOTHOLES . . .** Political history shaped in Philadelphia by the Republican National Convention provided the background for an important chapter of communication history when the largest single installation of television receivers ever assembled in one spot was undertaken.

The vast seating capacity of Convention Hall was further increased by the installation of 60 television receivers, in the Exhibition Hall of the Com-

mercial Museum to take the sights and sounds of the convention outside the walls of the Hall for an additional audience of nearly 2000 persons.

RCA engineers installed the 60 receivers in such a manner that 30 or more viewers were accommodated by each. The instruments were connected by coaxial cable to a battery of four television cameras mounted on a special balcony only 75 feet from the rostrum in Convention Hall.

This is the first time television has been used to increase the seating capacity of an auditorium. This setting up of "electronic knotholes" at important functions is a new application which may come into widespread use in the future.

★

**OFF THE RECORD . . .** Dealers in Discs will be interested to learn that Mr. and Mrs. Average American and Family seem to prefer serious music to swing or popular tunes, at least when they are able to hear the classics in their proper settings.

This was made known as the initial results were published of a survey made at the RCA Exhibit at the New York World's Fair, of requests for recorded music received in the building's Record Music Room. More than 1200 requests for selections are made on the average day and about 200 selections are played. During the first month of the Fair 83.5% of the requests were for serious music and only 16.5% for swing and popular numbers.

The survey represents a cross section of the country since visitors from every state in the union have registered their requests.

★

**JOBBER'S JOB . . .** There is nothing more important to a manufacturer than his jobber outlets. His system of distribution and its efficiency rests on jobber cooperation. Any manufacturer whose means of distribution ignores the jobber in his lines of communication to the consumer is operating outside of a system that has time and again demonstrated its worth in the American scheme of things.

To paraphrase an old saying, A manufacturer is known by the jobbers he keeps.

—EDITOR

# PHONO SERVICING



Set-up for checking speed of phonograph turntable with neon tube and stroboscope disc. Pickup is run through outside of record to establish normal load.

WITH close to a million record players of one sort or another in use, the maintenance and improvement of record-reproducing equipment has become more than a mere sideline for the serviceman. Moreover, aside from the possibilities in "doping up" existing equipment to improve response, replacement sales opportunities are larger than one would suspect. The fact is, the average person usually starts out with a cheap unit incapable of doing justice to modern recordings, and soon develops a yen for something better—a new electric turntable, a quality pickup, or possibly a more expensive amplifier and speaker system.

Whether this business goes to the dealer or the serviceman depends to a large extent upon the exercising of the educational factor. We mean by this that the serviceman should be fully equipped materially and mentally to use to his advantage the slightest complaint a customer may have against his record-reproducing equipment. If faults are explained to the customer, and, further, their presence demonstrated, the customer is very likely to give the serviceman a free hand in deciding what is necessary to provide optimum results.

## MATERIAL EQUIPMENT

As for material equipment, the service-

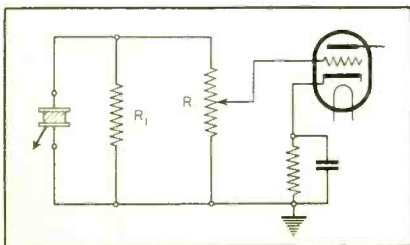

Fig. 1. The shunt resistor,  $R_1$ , will reduce turntable rumble by attenuating bass response of *xtal* pickup.

man should have a compact record player of good quality and known frequency response, to use not only as a check against doubtful pickups, but also as a demonstrator, to show the customer the improvement to be had from a good pickup. The motor and turntable should also be a quality product. If it is reasonably quiet and constant in speed, it, too, will serve to demonstrate the value of good equipment. From such direct comparisons, the serviceman can sell turntables and pickups of the same make as he employs in the "standard" player, and he should stock these units so as to be in a position to make immediate delivery.

The serviceman should also carry a stock of record cleaners, keep one in his kit, and use it before running a test on a customer's record. True, they are inexpensive, and the profit is small, but they have the value of creating good will if the serviceman uses them for the purpose of educating his customers into protecting record surfaces against dust and grit. If the serviceman uses a cleaner, the customer will feel that he also should.

Material equipment should also include a stroboscope disc and neon bulb for checking turntable speed, and a frequency test record for checking response. A stroboscopic test in the home is convincing and pretty conclusive, and may well induce the purchase of a new motor and turntable. A test with a frequency record will show up peaks in the reproducing equipment.

The serviceman should have at least one outstanding modern recording for use when making direct comparisons between pickups and determining the degree of frequency correction required to provide tonal balance. Any of the late Victor Red Seal recordings of the Boston Pops Orchestra are particularly recommended for this purpose. Any

pronounced peaks, harmonic distortion, or masking of one group of frequencies by another, will be quite noticeable after a few playings. A recording of this sort will quickly show up a poor pickup, or reveal the quality of a good one.

## MENTAL EQUIPMENT

The mental equipment is the knowledge the serviceman has but often fails to use. If it is to be useful, it should be spread around gratis. There's repeat business to be had from it, to say nothing of customer confidence. The specific knowledge can be placed under the heading of "expert advice," and includes the following points that should be stressed when the opportunity presents itself:

1) By virtue of its abrasive action, dust and grit deposits in record grooves will increase wear and surface noise under the action of the reproducing needle. Hence, do not leave record surfaces exposed. In any event, go over all records occasionally with a cleaner pad.

2) Do not store records near a radiator in the wintertime, or leave them exposed to strong sunlight. The heat will warp them. A warped record can often be straightened by warming it near a radiator or in sunlight, and placing it under pressure between flat surfaces.

3) Do not leave records in the holder of an automatic record player; they will warp, particularly in a warm climate.

4) A warped record will "wow" on the turntable of an automatic record player with drop mechanism, as there will be insufficient surface contact between records to provide constant grip.

5) A warped record, a record with a rough or chipped rim, or one with off-centered spindle hole, may jam the mechanism of an automatic player, or the record may fail to drop.

6) Sour music or variation of pitch may be due to, (a) slippage of record

on turntable, (b) excessive warpage, (c) variation in speed of turntable, (d) record spiral off-centered with respect to spindle hole.

7) If "wow" or variation in pitch is due to off-centered recording, it will be reflected in a lateral to-and-fro movement of the pickup arm which is easily seen. The fault may be corrected, though with difficulty, by enlarging the spindle hole with a penknife, in the direction of the maximum outward swing, and placing the record on the turntable with the bulge in the hole bearing against the spindle. This will compensate for the off-centering of the spiral provided the spindle hole is off-centered by the same amount.

8) There is nothing harder on records than a heavy pickup of the old type. Any pickup with a needle pressure exceeding 3 ounces should be replaced with one of the newer types.

9) With the exception of the more expensive ones, magnetic pickups are deficient in bass response, whereas crystal pickups overemphasize the bass. Hence, "motor rumble" from the turntable motor is more apparent when a crystal pickup is employed. However, this can be greatly reduced, if not eliminated, from the amplifier input if the bass response of the pickup is attenuated by an alteration of circuit values.

10) Few popular radio-phonograph combinations produced previous to this year employed frequency correction in the pickup circuit. The quality of reproduction of these combinations can be improved by matching the characteristics of the pickup with those of the amplifier and speaker with which it is employed.

11) Though it is not always apparent, "pickup chatter" comes from the pickup, not the loudspeaker, but is an annoyance nevertheless. A change of needle type may eliminate it, but the best answer is a record player with a lid that may be closed so that the "off-the-record" noise cannot be radiated into the room.

12) For those addicted to album music and disliking long breaks occasioned by manual turning, the neatest setup is dual turntables and pickups, with dual volume controls or a fader, and the use of album recordings pressed for automatic record players of the drop or throw-off type. In these pressings, the sequence progresses through one set of sides, then the other.

#### SERVICING

A frequent complaint is phonograph-motor rumble or "growling". This can be very annoying, particularly if the motor-turntable and pickup are a part of the radio rather than separate from it. In consoles having a high degree of cabinet resonance, the condition is further aggravated.

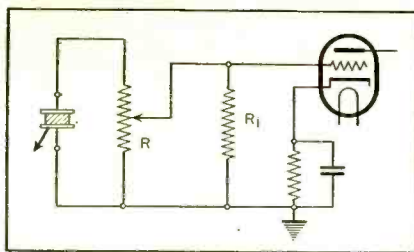

Fig. 2. With this connection, the load resistance alters with a change in the setting of the volume control.

Contrary to popular belief, very little of this rumble is transmitted to the reproducing unit of the pickup via the motorboard and the pickup arm. Modern phonograph motors are floated on rubber and pickup bases are rubber-insulated from the motorboard to prevent mechanical vibrations from reaching the reproducing unit.

Actually, gear noise, etc., is transmitted upwards through the turntable drive shaft, thence laterally from the spindle through the turntable and record. In modern machines, this lateral transmission of mechanical vibration through the record has been substantially reduced by employing a rubber spindle. The felt pad on the turntable also serves to insulate the record from laterally-transmitted vibrations.

Irrespective of these precautions, any lateral vibrations through the record will tend to displace the reproducing needle, the functional movement of which is lateral to begin with. Hence, gear noise, etc., affect the needle in the same manner as the modulated record grooves.

In fairness to the manufacturers of motor-turntables, it should be pointed out that the exceedingly close tolerances required to completely eliminate all vibration in the drive mechanism can be incorporated only in the more expensive units. The high response of crystal pickups in the bass region results in an emphasis of rumble or growl, and in this respect the crystal pickup has brought on a condition seldom encountered when a magnetic pickup is employed.

#### ELIMINATING RUMBLE

In the event that the motor-turntable is well designed, and not defective, rumble and growling are most readily eliminated by attenuating the low-frequency response of the crystal pickup. This is accomplished by reducing the value of the load resistance across the pickup, which is usually the volume control. Rather than replace the control with another of lower value, it is far easier, and just as effective, to add a fixed shunt resistor,  $R_1$ , as shown in Fig 1. An exact value for this resistor cannot be given, as it is dependent upon the total resistance value of the volume control and the degree of attenuation necessary to eliminate rumble. However, it has been determined that where the volume control,  $R$ , has a value of 500,000 ohms, a value of 75,000 ohms for  $R_1$  does the trick.

An alternative arrangement is shown in Fig. 2. Here the shunt resistor  $R_1$  is connected from grid to ground so that the load resistance alters with a

(Turn to page 26)



Equipment every serviceman should have—a frequency test record, a stroboscope disc, a neon tube for use with the disc, and a record cleaning pad. They're all handy and provide impressive tests.

# THE SHOW IN REVIEW

**D**ESPITE a varied assortment of monkey wrenches that have been thrown or carelessly dropped into the works of the radio industry, The 1941 Radio Parts National Trade Show, in Chicago, got off to a good start in the Stevens Hotel, on June 10th, and concluded a satisfactory run on June 14th.

Total trade show attendance reached a new high, with a registration of 8456. There was an increase of jobber firms registering at the show of 120, the total of individual jobbers being 587.

The number of exhibitors also attained a new high; 140 individual firms occupied 175 booths. There was not a single square foot of exhibition space remaining when the show opened.

Buyers were present from South America, Central America, Mexico, Cuba and Canada.

The Canadian delegation, numbering approximately 50, represented the vast expanse of territory extending from Montreal to Vancouver. During the show, the group held its first Canadian luncheon, arranged by John T. Rochford, of the *Radio Trade-Builder*.

The RSA held a one-day convention at the Stevens on the closing day of the show, though committee meetings and several board of directors meetings were held from the 11th on. At the evening session, on the 14th, there was a special servicemen's F.M. demonstration put on by Zenith.

The first formal trade show get-together of National Radio Parts Distributors Association was a dinner session on the evening of June 13th, attended by 101 jobbers.

The Sales Managers Club, eastern and western divisions, also met during the week. Joe Marty, of the RSA, and Art Moss, of NRPDA, were guest speakers.

One of the highlights of the show was the organization meeting of the "Old Timers Club." The idea to organize such a group was born in 1937, but it remained for John O. Olsen, Pittsburgh manufacturers rep., to make it a reality. Mr. Olsen is President and Ken Hathaway, trade show manager, secretary.

Membership is open to everyone who has been in radio for 15 or more years. More than 200 are already on the rolls, with a substantial number of others waiting to be added. There are no dues.

At the annual meeting of Trade Show corporation, the following four directors were elected: A. A. Berard, representing the Sales Managers Club, eastern division; H. W. Clough, repre-

★ **REPORT ON THE 1941 RADIO PARTS NATIONAL TRADE SHOW. NEW HOME RECORDERS, PICKUPS AND TEST EQUIPMENT WERE SHOWN. WAR AND F.M. INFLUENCE FIELD.**

sented the Sales Managers Club, western division; H. E. Osmun and J. J. Kahn, representing the Radio Manufacturers Association. Chairman of the nominating committee was S. N. Shure, retiring director.

## **NRPDA CONVENTION**

The annual meeting of the Directors of the National Radio Parts Distributors Association was called to order on Monday, June 10th. Of the board of 21 Directors, 20 were in attendance. Mr. Walter C. Braun, President, presided.

Reports of the committee and Treasurer were read and approved. A full discussion of the future plans of the Association followed. To carry out the program laid down, the Directors unanimously decided to revise the dues schedule in order that sufficient revenue could be depended upon. The revised schedule is as follows: Sales of \$25,000 to \$50,000—\$35.00; sales of \$50,000 to \$100,000—\$75.00; sales of \$100,000 to \$200,000—\$125.00; sales of \$200,000 and over—\$200.00.

It will be seen that dues in the lowest bracket, which comprises over 75 percent of the Association membership, was increased \$10.00 annually, whereas all other brackets were proportionately higher, and the larger concerns voluntarily increased their dues 100 percent. On the above basis, the Directors figured a minimum income would be received to carry on the essential activities of the Association.

Sectional group meetings have proven to be very effective, and it is the immediate aim of the NRPDA to establish sectional chapters in every important trading area in the United States.

A nominating committee composed of W. O. Schoning, Chairman, and W. C. Braun, A. Lippman, A. Stallman, Wm. Shuler, and Elliott Wilkinson, was appointed to submit a suggested slate of seven Directors to the membership meeting.

The report of the nominating committee recommending the re-election of the seven Directors whose terms expired was approved, and these Directors were re-elected. The membership was advised that commencing with 1941, the Board recommended that seven new Directors be elected who had not previously held office.

The new Board of Directors retired

to elect the officers for the coming year, and the following were unanimously chosen: President, George Barbey; Vice Presidents, Elliott Wilkinson, Abe Davis, Alex Hirsch, and Aaron Lippman; Treasurer, William Schoning; Secretary, John Stern.

The Directors advised that Arthur Moss had again been retained as the Executive Secretary.

## **ATMOSPHERE**

The atmosphere of the show had a slightly chaotic tinge, which is not surprising in view of the fact that conditions in general are chaotic, due to World War II. The recent restrictions placed on amateur transmissions to foreign countries, and local portable-mobile operation below 56 mc, have temporarily depressed the amateur transmitting equipment market in which many parts manufacturers have a stake. Though we expect a resumption of buying once the initial impact of the measure has worn off and the amateur appreciates the fact that his activities have not been at all drastically curtailed, the immediate result in the parts field may be a period of marking time.

Manufacturers ordinarily employ the trade show for introducing their new equipment and components. Many did so this year, but production on f-m and television receivers and equipment for their servicing was held up due to the tardiness and vacillation of the FCC in arriving at a conclusion regarding the future of these services and the frequencies assigned to them. Hence, much new equipment is yet to be announced. The products introduced at the show are covered elsewhere in this issue.

## **HOT**

Hottest things at the show were frequency modulation, which has captured everyone's interest, inexpensive home-recording equipment, paging equipment, high-impedance circuit measuring devices, "vest-pocket" receivers employing the miniature dry-cell tubes, and Philco's photo-electric phonograph pickup.

As time passes, the value of frequency modulation is more fully appreciated. It solves a host of old problems and is destined to click with the public.

(Turn to page 25)



# Serviceman's Diary

By J. P. HOLLISTER

**T**HURSDAY—Arrived early and found Jerry, as usual, already on the job. The floor had been cleaned, the cigarette butts dumped out of the ash-trays and, at the moment, he was polishing the "Ladies" sign hanging on the door to the shop in the rear. This sign sure was a good idea. We tried "No Admittance," then "Positively No Admittance" with equally unsatisfactory results. They just aroused curiosity. With the new sign, no man, not even a Fuller Brush salesman, strives to barge into the shop. And the few misguided women who innocently cross the sacred portals invariably depart hurriedly after a startled glance at the male inhabitants at work.

I grabbed the two calls off the hook and started out, stopping off at the gas station to have the oil changed. Tony showed me his new battery-charging panel, all fixed up with new, shiny meters and two big Tungar rectifiers. He should have had it last winter when he had a lot of dead batteries to handle. We could have sent him some, too, since the small 5-ampere job down at the shop is too slow for auto batteries, although it does serve to keep our test batteries up for the little auto-radio work we have.

First stop was at the K—'s, who live on the top floor of a large apartment house down by the ocean. I sort of had a hunch there would be a call-back on this job. The set is a Motorola 89-K2, one of those motor-driven, push-button-operated, remote-control affairs with a clock on the front of the console. When I called there two weeks ago, the complaint was that they couldn't turn the set off without pulling the plug or operating a toggle switch at the rear of the chassis. I found that the lead connecting to the solenoid on the on-off relay

had come adrift, so I simply resoldered it back on the same spot where it came off. I wondered afterward just how they could use the set for nearly a year without any trouble showing up and then suddenly find that the lead had come off. And now it's down with the same complaint.

Mrs. K— wasn't in, which was a break for me. You always have to make apologies and sometimes they seem to think you have done them a personal injury. I sure thought I had put enough solder on the joint this time to make it hold indefinitely. I hoped that the relay itself had burned out.

The maid let me in and we chased the two Scotties out of the living room before I went to work. The last time I called the dogs were asleep on the rug and I didn't pay much attention to them. However, while I was taking out the chassis, one of them ambled over and noticed my foot protruding at one side of the console. The dog sniffed it and apparently mistook it for an unfamiliar post. He was about to identify it for future reference in the usual manner, but I got the foot out of the way in time. So now I take no chances.

I removed the bolts and knobs and slipped out the chassis. Same trouble as before—the wire was adrift. I got out the soldering iron and plugged it in the line supply receptacle, taking the opportunity to grab a smoke while it was heating. (Funny how long it takes for an iron to get hot when you're not doing anything!) When it finally did get hot enough, I cleaned the solder off the electromagnet core where the wire had been connected and found that the connection had actually been made to the head of a screw. This time I got the core hot enough so I could loosen the screw, wound the wire around the screw head

and made the connection mechanically tight before soldering again.

This was all that was necessary. The set worked and the relay tripped without trouble. I noticed that the relay coil got hot when the "off" button was held down for any length of time, which provided a clue to the cause of all the trouble. The heat simply softened the solder and off came the connection. It can't happen again.

The next call was at the M—'s place, just three blocks away. The big Stromberg was noisy. Checked the lead-in strip at the window, as usual, with the set going full blast. It was OK, but when I reached out the window and wiggled the lead-in itself, plenty of noise resulted. They had an extension ladder in the garage, saving me a trip back to the shop, so I ran it up against the house and examined the joint to the aerial. Somehow it had worked loose, quite probably because it never had been soldered. I got the blow-torch going and sweated on a good joint. While I was at it, I replaced the spring in series with the antenna and the house and took up a little of the slack in the antenna. Too often, after an antenna repair job, we get a windstorm and down comes the whole affair.

When I had finished, Mrs. M— asked me if I would mind looking at Alfred's little crystal set. I would mind, but there wasn't anything I could say about it. I'd much rather shoot trouble on a 25-tube f-m set than fuss around with a crystal. In fact, the kid could locate the sensitive spots on the crystal quicker than I. However, I checked the phones with the ohmmeter, listening for the click. They sounded all right. Then I hooked the set to the big antenna—he had been trying to use it on a short,

(Turn to page 25)

## HORACE—

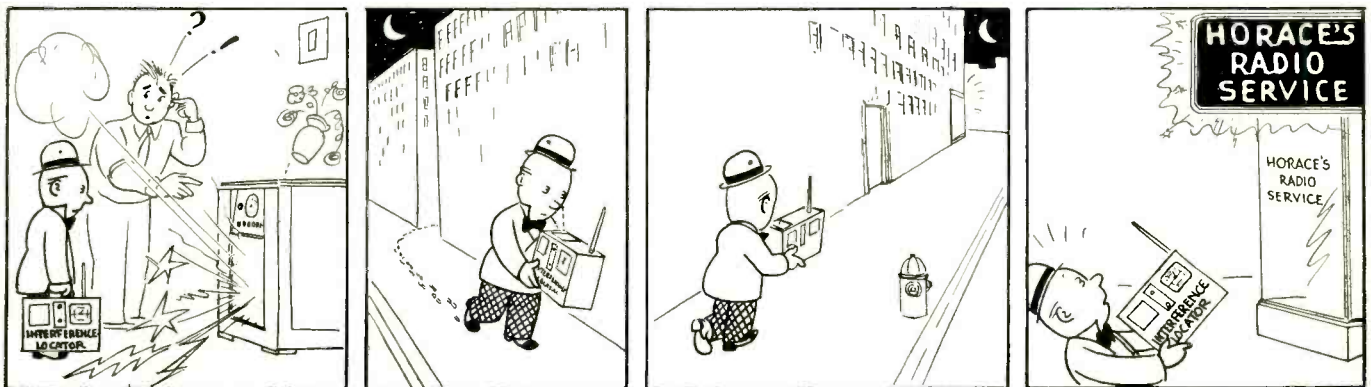

# ELECTRONIC GADGETEERING

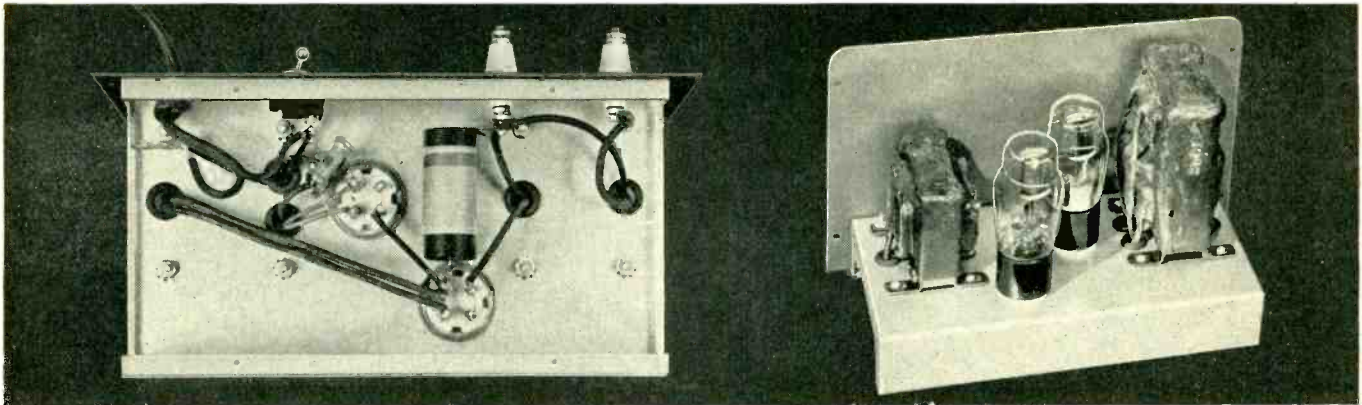

Fig. 1. Rear and bottom chassis views of the completed a-c fence controller.

**I**F you are located in a rural community, spend your vacation in such surroundings, or have your place of business within striking distance of the open spaces, then you can profit by resorting to a bit of Electronic Gadgeteering.

Take fence controllers, for instance—those high-tension gadgets by which stock men, farmers, gardeners and country gentlemen, can keep the livestock home and discourage outsiders. They're simple, neat, effective, easy to construct, easy to sell and install, and applicable to places within or beyond the power lines. One type operates from 110 volts a.c., another from a 6-volt "hot-shot" or 6-volt storage battery. You can build a brace of 'em for demonstration purposes and really go to town.

## A-C CONTROLLER

Rear and bottom views of a completed 110-volt, 60-cycle operated fence controller are shown in Fig. 1. This unit employs a Cetron discharge tube, an 80 rectifier, a neon indicating tube, a power

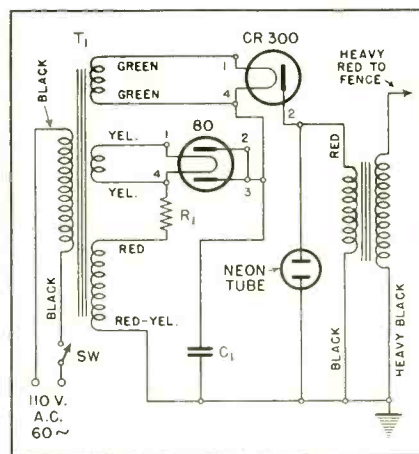

Fig. 2. The a-c fence controller circuit.

## A-C CONTROLLER PARTS LIST

- T1—Stancor P6127 power transformer
- T2—Stancor P6126 high-voltage transformer
- R1—Fixed resistor, 1 megohm, 1 watt
- C1—Fixed 0.5 mfd., 600-volt paper
- SW—S.P.S.T. toggle switch
- Cetron CR-300 discharge tube
- Type 80 rectifier
- Neon tube, 1/4 watt
- Cabinet—Stancor H1
- Chassis—Bud CB-276 or ICA 1530

transformer and a high-voltage transformer. The transformers are impregnated against moisture, an important consideration when the device is installed in the open.

The operation of this device is simple. Referring to the schematic, Fig. 2, a d-c voltage is applied to the condenser *C1* through the series resistor *R1*. When completely charged, the condenser is then discharged through the primary of the transformer *T2* by the Cetron tube. The resultant surge builds up a relatively high secondary voltage which is in turn applied to the fence.

The entire process is repeated at a rate predetermined by the values of *R1* and *C1*. The discharge rate varies inversely with the value of *R1*. For example, this resistor, which has a value of 1 megohm, produces approximately 55 discharges per minute. If its value were changed to 2 megohms, the rate would be approximately 28 discharges per minute.

In application, one side of the secondary of transformer *T2* is normally connected to a single fence wire insulated from ground. The other side of the secondary is connected to the chassis, which in turn should be well grounded for best results.

## CONSTRUCTION

The chassis specifications are given in Fig. 3. This arrangement was used in the original model, although it may be changed to meet individual requirements. Leads passing through the chassis should be protected by rubber grommets. All ground connections are made directly to the chassis which in turn is connected to a good external ground, such as a well casing or underground water pipe. Line cord, output terminals and control switch are all conveniently placed on the front panel.

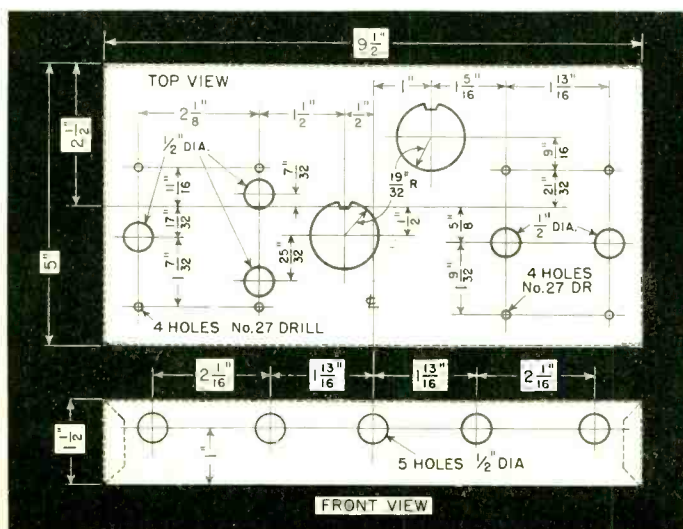

Fig. 3. Complete chassis specifications for the a-c fence controller. All leads passing through chassis should be protected by rubber grommets.

# IN FENCE CONTROLLERS

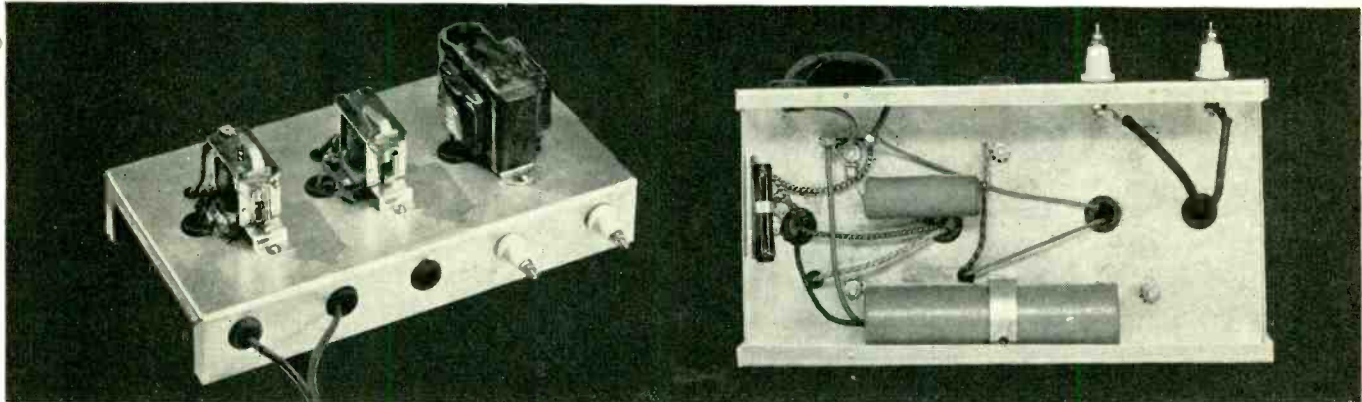

Fig. 4. Top and bottom views of the completed d-c fence controller unit.

## D-C CONTROLLER

This controller, operating from a 6-volt battery source, utilizes a high-tension fence transformer and two relays in a clever and efficient circuit arrangement. Top and bottom views of the completed unit are shown in Fig. 4.

The manner in which this controller operates can be gained by reference to the schematic, shown in Fig. 5. Closing switch *SW1* causes a current to flow through the variable resistor *R1* and *Relay 1*, thereby charging condenser *C1*. The charging current through *Relay 1*, which is the normally closed type, causes the contacts to remain open until the current falls to a value too low to hold the armature. When the contacts on *Relay 1* close, a circuit through condenser *C1* and the open-circuit *Relay 2* is completed, causing contacts on *Relay 2* to close. Condenser *C1* then discharges almost immediately through *Relay 2*, but during the brief interval the contacts are closed, transformer *T* is energized by the 6-volt battery, and when *Relay 2* opens, breaking the 6-volt circuit, a high voltage is induced in the secondary of *T*. The timing of the discharge intervals is predetermined by the parallel resistance value of *R1* and the relay coil, together with condenser *C1*. Decreasing the value of *R1* will increase the number of shocks delivered to the fence per minute.

As with the a-c controller, the hot side of the transformer secondary is connected to the fence to be controlled, and the grounded side (chassis and battery) connected to a good external ground.

## CONSTRUCTION

Chassis specifications are given in Fig. 6. Due to the operating characteristics of the relays, a novel method of chassis layout is used in this unit. This method permits the relays to operate in the cor-

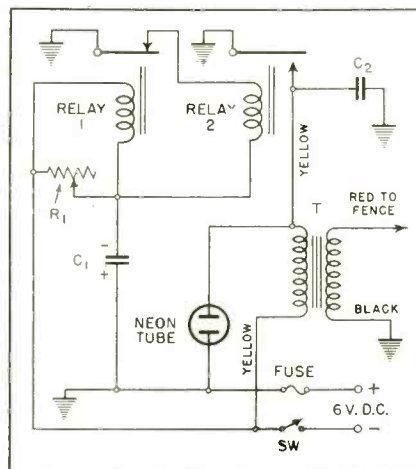

Fig. 5. Schematic diagram of the d-c fence controller unit. An a-c voltage is developed in the transformer *T* by means of relays which make and break the circuits.

## D-C CONTROLLER PARTS LIST

T—Stancor P6122 high-voltage transformer  
 Relay 1—Guardian No. 13230  
 Relay 2—Guardian No. 13229  
 R1—Variable wire-wound, 1500 ohms, 10 watts  
 C1—Mallory HC1210 electrolytic, 1000 mfd., 12-volt d.c.  
 C2—0.25 mfd., 600-volt paper  
 Neon tube, ¼-watt  
 Cabinet—Stancor H1  
 Chassis—Bud CB-276 or ICA 1530

rect position, with armature hinge down. It also provides sturdy support for all units.

Layout may be changed to meet individual requirements. Grommets should be used to protect all leads where they pass through the chassis.

Battery leads, neon indicator and output terminals extend through the front of the panel for cabinet mounting, or may be arranged through holes drilled in the lower apron of the chassis, and the entire unit mounted against a wall.

## INSTALLATION

These controllers deliver a very hot, penetrating shock when touched, and cattle will give the charged fence wire a wide berth. Be sure the fence is well marked by a warning sign. The livestock won't heed it, but people in their right mind will.

Before installing a fence controller, investigate your local and state regulations covering the operation and use of such equipment.

Suitable precautions, such as lightning arrestors, fusing, etc., should be taken before the unit is placed in service.

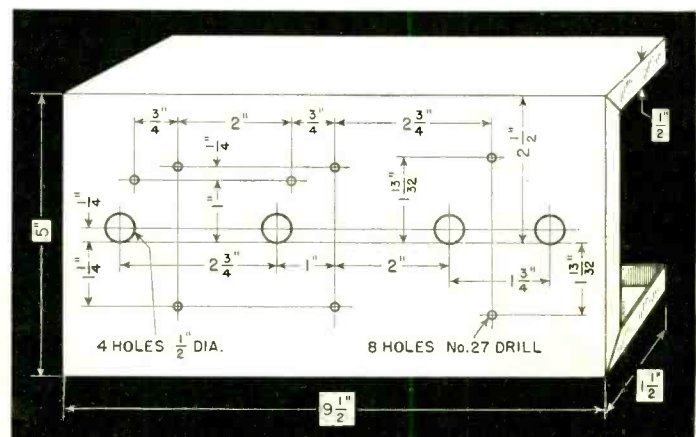

Fig. 6. Complete chassis specifications for the d-c fence controller. All leads passing through chassis should be protected by rubber grommets.



# TECHNICAL SERVICE PORTFOLIO

## SECTION III—DATA ON CONDENSERS

**D**URING a lecture held by an engineer of a condenser company, one serviceman complained: "When a radio set goes wrong, it is usually the condenser." This general idea also seems to be shared by the average set-owner who thinks that any trouble is caused by the condenser and wants to know how much the condenser will cost.

Yet, the condenser is a reasonable animal, and will behave well when treated right.

It is hoped that the following information will help the serviceman to use condensers to the best advantage. It covers the various types of fixed condensers used in receivers only. They may be divided into three groups: electrolytic condensers, paper condensers and mica condensers.

### ELECTROLYTIC CONDENSERS

The electrolytic condenser consists of two conductors separated from each other by an electrolyte. When a direct current is passed through such a unit, electrolysis takes place and a thin film is formed on the positive electrode. Since this film is a bad conductor, when it has become thick enough the current will reduce to a very small amount and the unit acts as a condenser as long as the polarity of the applied e.m.f. is not reversed. Due to the fact that the formed film is very thin, the capacity per square inch of foil is very large, which makes it possible to obtain a large condenser of small dimensions and low cost.

The electrolyte of the condenser, as explained above, is not the dielectric, but it serves as a conductor between the negative foil and the film. Usually the film is formed on the foil before the condenser is assembled. This "pre-forming" is done at a voltage slightly higher than the condenser will later have to stand. The higher the forming voltage, the thicker the film has to be and, therefore, high-voltage condensers require a greater area

of foil per microfarad than those of low-voltage.

There appears to be an upper limit for this formation voltage; about 600 volts. Electrolytic condensers for higher voltages would have to be built up by employing two or more units in series.

### WET ELECTROLYTICS

In the case of wet electrolytics, the electrolyte is in liquid form while the can is usually the negative electrode. Large high-voltage condensers can be made most economically in this form. There has been a trend lately towards increasing the capacity of filter condensers in power packs and reducing the size of the chokes so as to get the same filtering action at less expense. Wet electrolytics up to 80 mfd. are in use here.

Wet electrolytic condensers have some properties of their own. In the first place, they have to be mounted vertically. Some of them can be used in other positions for short periods, as during a service job, but they cannot be used that way permanently.

This type of condenser is subject to a phenomenon called "scintillation" which is best explained by reference to the curve of Fig. 1. When the applied voltage is increased beyond the peak-voltage rating, the leakage increases, and finally a point is reached where the film breaks down. When the electrolyte touches both foils again, formation takes place and it breaks down again. The process repeats rapidly

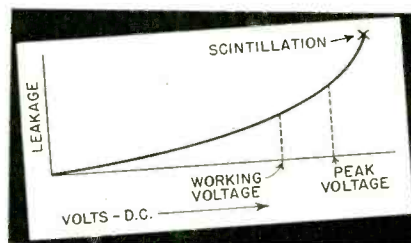

Fig. 1. Film breakdown curve of a wet electrolytic condenser.

and when the voltage is lowered again, the condenser is still good. A dry electrolytic would simply break down and that would be the end of it.

When a wet electrolytic condenser is not used for some time it gradually loses the formed film at the anode. Placing it in service again is accompanied by forming the film anew and this means a heavy initial leakage current which gradually diminishes. In order to prevent damage to the power supply, such a condenser should not be connected without a series resistance to limit the initial current. Such a resistance should be of a size determined by the capacity:

$$R = \frac{20,000}{C} \text{ ohms}$$

where  $C$  is in microfarads.

It should now be clear that a large wet electrolytic condenser should not be placed immediately after the rectifier in a power pack, especially not after a mercury-vapor rectifier, or a close-spaced rectifier such as the 83V, the 5Z4, or a 25Z6. If the receiver were idle for a month or so and then used, the initial leakage current would become so high as to cause damage to the rectifier and the transformer. There is probably little danger with such rectifiers as the 5Z3 and the 80 because they have a relatively high internal resistance.

The large electrolytic condenser can be used as the second or third condenser in the power-supply filter because the choke or speaker field will then have enough resistance to limit the current. In such a case, one may expect a large voltage drop in the choke and a low output voltage during the forming period.

### DRY ELECTROLYTICS

In a dry electrolytic, the electrolyte has been soaked up in some inert substance used as a separator, such as surgical gauze. This type of condenser does not

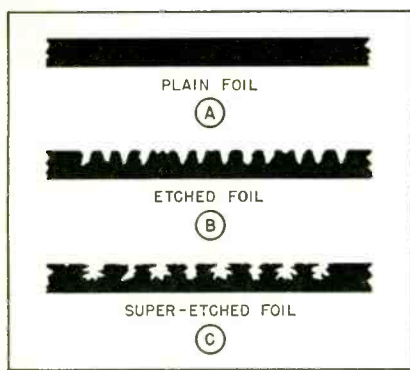

Fig. 2. Plain, etched and super-etched foils as used in dry electrolytics.

exhibit the scintillation phenomenon. Moreover, it can be mounted in any position and does not lose its formation so easily. Another advantage is, that several sections can be placed in one can and that both terminals or foils may be isolated from the can.

In the "etched foil" electrolytic condenser, the area of the foil, Fig. 2A, is increased by burning grooves into the foil with acid. This is illustrated in Fig. 2B. An increase in effective area of from 3 to 5 times is possible in this way, thus permitting a larger capacity for a given size.

The art has already progressed to a point where they are "etching the etchings," as in Fig. 2C. Such foils are beginning to have the porous form similar to the old storage battery plates.

Although such condensers do exhibit the preferred quality of low cost and small size, it does not mean that the old straight foil type should be forgotten. The etched foils have a greater resistance and such units have a greater power factor. In general, they are more sensitive to overvoltage and overheating and have a shorter life than the old type.

The following discussion applies to all types of electrolytics:

When electrolytic condensers are exposed to raw a.c. or to the wrong polarity, or when the power factor becomes too high, electrolysis takes place and a malodorous gas is formed. The condenser is provided with vents to let this gas escape so as to prevent an explosion. In most dry types the vents are covered with a paper sticker which tears when the pressure inside becomes too high.

Electrolytic condensers of all types are sensitive to heat, regardless of its source. It might, for instance, be generated inside the condenser by a large alternating current component in a unit having high power factor, or it might come from another nearby hot part by radiation, conduction or convection. When the condenser becomes warm, the leakage and power factor increase. This causes more heat, etc.

For the above reason, it is undesirable to place an electrolytic condenser close to a rectifier or other hot part. Also, the heat generated by the a-c ripple current should be watched and provision made for its radiation.

A maximum of 1 watt has been quoted as the limit for a condenser in a large can when the can is tightly fastened to a metal chassis. The safe limit for cardboard units is far less, especially if they are buried under many other parts in crowded quarters.

Condensers which are used in power-supply filters may have a rather large ripple current passing through them. Due to the fact that the power factor is not zero, this current causes heat development. The amount of power transformed into heat may be roughly estimated.

Very complicated equations may be derived for the magnitude of the ripple voltage and current, but it may be taken that the a-c ripple current through the input filter condenser of a power pack is approximately equal to the direct current drawn by the load. Suppose this to be 100 ma. The reactance of an 8-mfd condenser at 120 cycles is 166 ohms and if the power factor were 10 percent the equivalent series resistance would be 16.6 ohms and the power transformed into heat would be .166 watt.

This power transformed into heat is proportional to the power factor and inversely proportional to the capacity of the condenser. Since 10 percent power factor is already far beyond the rating of a good condenser, it is seen that the one-watt limit will, in general, not be exceeded.

When several condensers are in the same unit, each of them having some losses, and when they are also subjected to heat from other parts, trouble may arise.

Sometimes several units are in one can. They are not always positioned so that each has the same capabilities of heat radiation. Suppose they are located as in Fig. 3. The middle section has less chance to radiate heat than the end sections, and in case of trouble this is the first section to fail.

**RATINGS**

An electrolytic condenser has two voltage ratings, one called "normal working voltage" and one "peak voltage." In normal use, the d-c polarizing voltage plus the peak of the highest a-c component to



Fig. 3. Section 2 is more apt to fail, due to reduced heat radiation.

be expected should not exceed the normal working voltage rating. The leeway between this rating and the "peak voltage" rating serves to take care of emergencies such as surges caused by turning equipment on and off.

An electrolytic condenser which is being used at a voltage considerably below its normal working voltage, gradually loses its formation for this potential and changes to one of a lower voltage rating. At the same time the capacity increases. The process takes a long time to complete—at the normal rate of use, about a year. When such a condenser is then used again at its higher rated voltage, a re-forming process takes place, accompanied by relatively high leakage current.

**TESTS ON ELECTROLYTICS**

There are three quantities to be measured on electrolytic condensers: capacity, power factor and leakage. Several bridges are now on the market for the measurement of these quantities.

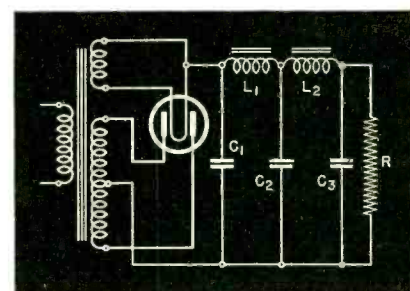

Fig. 4. Watch power-supply condenser capacities.

It is very difficult to give rejection points for leakage and power factor since these depend on several variables. Such recommendations have been given by some of the manufacturers; these are compromises at best since each case would have to be judged by its own merits.

**Leakage:**—When applying the leakage test one should watch the change of leakage with time, if there is any. According to the explanations above, a condenser may be on its way to re-forming with a decreasing leakage. In such cases one should wait until some steady figure is obtained. It is generally stated that this should be no more than .1 or .2 ma per microfarad.

An increasing leakage indicates a defective condenser which should be replaced.

**Capacity:**—Measurements of capacity are also best made with a bridge. Some bridges are available which apply a polarizing voltage to the condenser, others work on 30 to 60 volts raw a.c. High-voltage units are not damaged by this a.c. if applied for short periods, but it cannot be very good for the low-voltage units. Moreover, the capacity and power factor

are different with and without polarizing voltage. The capacity varies also with the applied ripple voltage. Accurate measurements can only be had if the unit is measured under the same conditions it will encounter in use; that is, with the same polarizing voltage, the same ripple voltage and the same frequency. It should then be no surprise to find that the same condenser measures different on different instruments; they may both be right. The magnitude of these differences are unimportant from the serviceman's standpoint.

**Power Factor:**—The power factor of the electrolytic condenser varies considerably with the polarizing voltage, the applied ripple voltage and the frequency and waveform of the ripple. It is as variable a quantity and as hard to measure as the inductance of an iron core coil which has d.c. flowing through it.

The greatest change is with frequency, the power factor being approximately proportional to frequency. Since most bridges work at 60 cycles and the condensers are used with 120-cycle ripples, the power factor of the condenser in a 120-cycle filter is twice the value obtained on the bridge. A good condenser will not show more than 2 or 3 percent power factor on your bridge. Here again one should not expect different type instruments to read alike.

**CONDENSERS IN POWER PACKS**

Consider a simple power supply, as in Fig. 4. Forgetting for the moment about the input condenser, the size of the second and third condensers determines the amount of ripple at the end of the filter. The attenuation of one filter section is very nearly equal to

$$\frac{1,000,000}{(2\pi f)^2 LC}$$

where  $f$  is in cycles,  $L$  in henries and  $C$  in microfarads.

The remaining ripple is then inversely proportional to the capacity of condenser  $C2$  in Fig. 4, and also inversely proportional to the capacity of  $C3$ . A large output condenser is desirable not only to reduce the ripple, but also for the improvement of regulation and to aid in the reproduction of low notes.

When one calculates and measures the effect of power factor in these condensers, it is found that even a 20-percent power factor does not affect the filtering efficiency appreciably. There is then no advantage in replacing these units with paper condensers of the same capacity from the standpoint of filtering efficiency. If they are replaced by paper condensers or any other kind of condenser of lower capacity, the ripple voltage at the output of the filter will rise.

The effect of the first condenser,  $C1$ , is more complicated. It helps to reduce the ripple voltage at the input of the filter and also to keep the voltage up, but these effects are not proportional to the capacity. There is a maximum capacity above which it is not economical to go.

Figs. 5 and 6 show two curves of capacity versus output voltage and ripple. Here it is obvious that a condenser size greater than at  $A$  does not give fair returns. This value at  $A$  depends on the total drain of the power pack. According to measurements made recently, one may set this as 1 mfd per 25-ma drain.

For the average radio set there is then little reason to go above 4 mfd at the input of the filter. A higher value has certain disadvantages. It concentrates the charge of the condenser to a smaller part of each cycle and therefore increases the peak rectifier current and also causes less efficiency in the transformer. The transformer and rectifier will run cooler if the first condenser is held down in size.

Apart from the above considerations, it has been found that close spaced rectifiers, such as the 25Z6 especially, should

not be followed by a large condenser. There is then a chance that the emissive cathode coating will be deposited on the plate. Thereafter the rectifier conducts in both directions and the large a-c component ruins first the condenser, then the rectifier. This phenomenon takes place when  $C1$  is of the order of 30 mfd.

**PAPER CONDENSERS**

Wax-impregnated paper condensers consist of two metal foils separated by two or more waxed papers. The number of papers and their thickness determines the voltage rating, but there are never less than two since an accidental hole in a paper might otherwise cause a short. The whole is then wound up to form the familiar tubular or it may be in a flattened form to be put into a can.

The so-called non-inductively wound condenser has the long edge of the foils sticking out at each side of the paper. When rolled up, the terminal is soldered to the whole side instead of to just one point. Thus the current passing through the condenser does not have to run the length of the foil, which, being in the form of a spiral, would constitute an inductance. Among the defects that servicemen should watch for is the working loose of a part of these ends. Such a condenser tests normal on d.c. and on low-frequency a.c. but the trouble shows up at radio frequencies.

The voltage rating of the condenser can be exceeded for small periods without a breakdown. However, running the unit constantly at a higher voltage than its rating results in a shortening of its life. It is estimated by some authorities that the life is inversely proportional to the fifth power of the applied voltage. In other words, running it at twice the rated voltage would divide the hours of its life by 32. Other authorities claim that the seventh power should be used instead of the fifth.

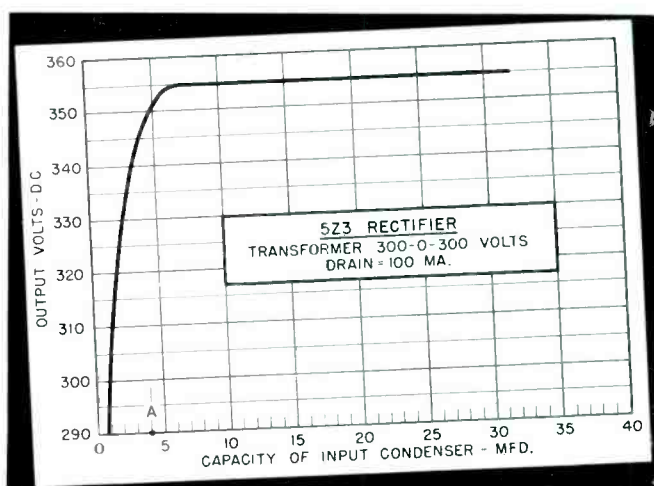

Fig. 5. Curve of capacity versus output volts.

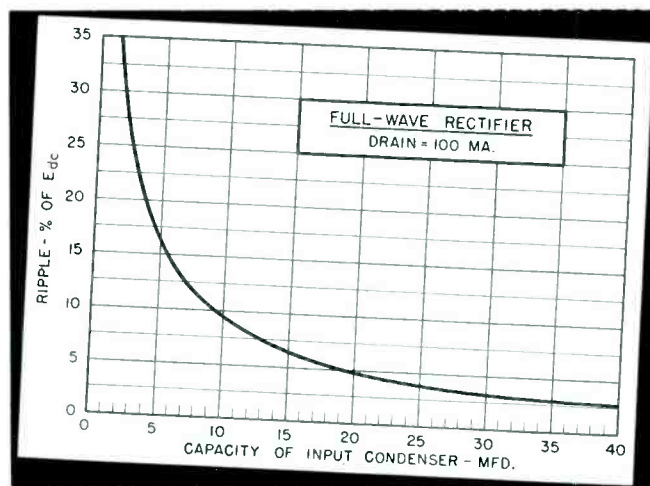

Fig. 6. Curve of capacity versus ripple percentage.

TESTS

The tests on these condensers are usually confined to tests for opens and shorts and measurements of capacity. In certain cases insulation resistance and power factor or Q are measured.

The capacity and power factor are independent of the magnitude of applied voltages and vary but little with frequency. The measurements made with different instruments should check.

Recently some instruments have been introduced which will test the condenser for an open and short, and for capacity, without disconnecting the condenser from its circuit even though it may be connected across another condenser or a resistor. Strange to say, that works. Such an instrument will also indicate a condenser which has a low Q or which is inductive due to the solder at the end having come loose.

Measurements for insulation resistance have to be made separately by an instrument similar to the one shown in Fig. 7. This factor is of little consequence except in coupling condensers for resistance-coupled amplifiers. Any leakage in such units results in a positive bias on the grid of the next tube which may counteract and even exceed the bias provided by the circuit.

The circuit of Fig. 7 serves to measure this quantity. It consists of a 55 tube or other suitable triode—preferably with a top grid connection—which is normally biased. A milliammeter indicates its plate current. The condenser under test is connected between the grid and the high side of a high-voltage supply, after first having been charged. Any leakage will now result in a change of bias and a consequent change in plate current. In order to save the tube in case of a bad condenser, the high-voltage supply has its positive side connected to chassis; hence, a leaky condenser will make the grid negative instead of positive.

The milliammeter can be directly calibrated in megohms for any given high voltage and size of grid leak.

When using this test instrument some

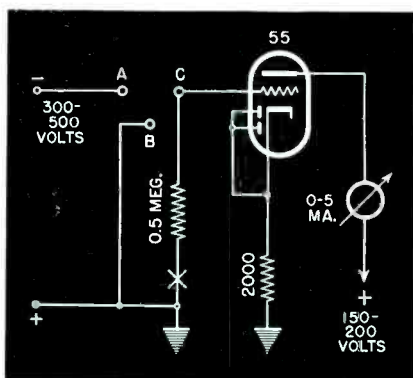

Fig. 7. Circuit for measuring insulation resistance.

precautions have to be taken. First, the condenser should be charged across the terminals A-B, then connected across the test terminals A-C. This can be done by hand, as all three terminals may end in clips on the panel. Shorted condensers should already have been eliminated by a short test.

The high voltage power supply should have good regulation, for any variation in voltage will show up in exaggerated readings of the milliammeter. For this reason a battery supply is often used. The power supply should also be free of ripples because a-c components will also cause a change in plate current.

Calibration may be carried out from a d-c source. Suppose the negative voltage supply to be 500 volts and the grid leak 0.5 megohm. Then, an insulation resistance of 250 megohms in series with the grid leak across the high-voltage supply will cause a drop of 1 volt across the grid leak. Then we might insert 1 volt d-c at X and mark the meter reading 250 megohms. Similarly, a ¼-volt change of grid voltage would be equivalent to 1000 megohms.

The insulation resistance to be expected depends on the size of the condenser and the limits are usually expressed in "meg-mikes"; i.e., the product of the insulation resistance in megohms and the capacity in microfarads. New condensers should read 2000 meg-mikes

or better. Otherwise, a low insulation reading does not mean that the condenser is useless because even a 10-megohm reading will not make much difference in a bypass condenser but it makes plenty of difference in a blocking condenser. Low readings spell future trouble, and condensers should be replaced immediately.

During the test, the condenser will appear to improve; a standard time interval of 2 minutes is allowed before making the reading. If the meter moves the other way, towards decreasing resistance, the condenser should be replaced.

MICA CONDENSERS

The ordinary mica condenser simply consists of two metal plates separated by a piece of mica. The whole unit is then moulded into bakelite.

Such condensers have a high Q, a high voltage rating, and are more constant in capacity than the other types. The ordinary type will change its capacity slightly during changes of heat and humidity until it has gone through several cycles and will then settle down to a constant value. The insulation resistance also improves with use; a new mica condenser placed in a resistance-coupled amplifier will generally have a lower insulation resistance than an equivalent paper one. However, the paper condenser gets worse with use, the mica condenser better.

The recent "silvered mica" condenser has its metal conductors deposited on the surface of the mica by a chemical process. Such condensers are unusually constant in capacity and need no aging.

TESTS

Mica condensers are tested for shorts, opens, capacity and Q. Since the measuring equipment available to the serviceman falls off in accuracy at small capacity values, it is recommended that the measurements be made at radio frequency. An approximate indication of Q can then also be had.

A suitable test instrument is shown diagrammatically in Fig. 8. An oscillator is loosely coupled to a tuned circuit consisting of a coil and variable condenser which in turn is connected to a vacuum-tube voltmeter or detector. When the tuned circuit is in resonance with the oscillator, the detector will show a maximum reading. The condenser under test is connected across the condenser C and the circuit re-tuned for resonance. The difference in the condenser setting equals the capacity of the unknown condenser. Condenser C can be calibrated in microfarads. Also, the better the response on the v-t voltmeter for any given coupling, the better is the Q of the condenser. A working frequency of 500 kc is satisfactory.

J. M. Borst

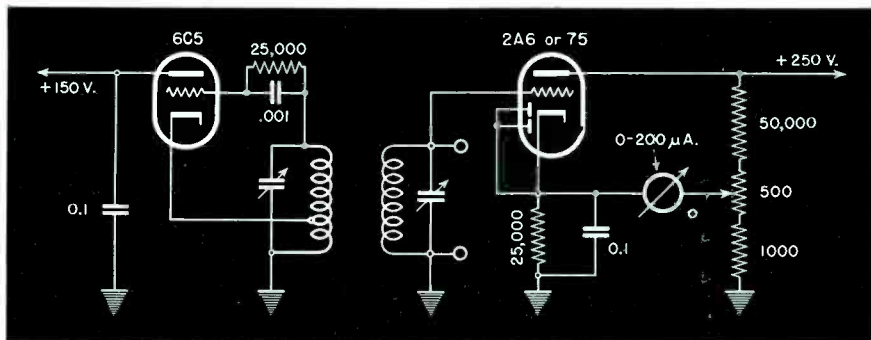

Fig. 8. Set-up, using oscillator, for testing condensers for opens, capacity and Q.



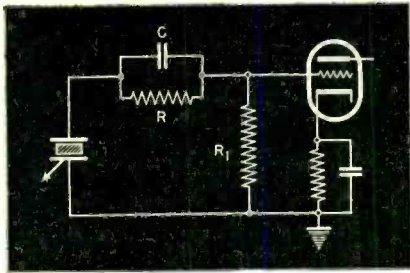

Fig. 5. Crystal pickup circuit containing an equalizer made up of the condenser C and the resistor R. R1 is the load resistor.

value is .01 mfd or greater, in which case its only role would be that of a blocking condenser. At lower values, however, its reactance to the higher frequencies increases; hence it can be of value in ironing out a secondary peak, if one exists. Normally, this condenser is not required.

So-called equalization can be obtained with the circuit shown in Fig. 5. With proper values for R, R1 and C, substantially flat response over the range of the pickup can be had. The resultant tonal balance provides a marked improvement in the reproduction of the more modern recordings.

Here again, precise values cannot be given as they depend upon the characteristics of the pickup and the amplifier and

speaker through which the pickup is operated. R1 (generally the volume control) may be anything from 0.5 to 2 megohms; the higher the value, the greater the bass response. A satisfactory value for C is 100 mfd. The resistor R determines the degree of bypassing around condenser C which presents a high reactance to frequencies in the upper range. Hence, the larger the value of R the greater will be the attenuation of the higher frequencies, and, conversely, the lower its value, the less the attenuation. Values generally used are 0.5, 1 and 2 megohms.

This equalizer should not be connected at the output of the pickup, but as near to the grid of the a-f tube as is practical.

Magnetic pickups with inadequate re-

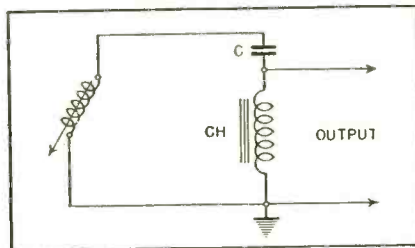

Fig. 6. Increasing bass response of magnetic pickup by means of a resonant circuit composed of a choke, CH, and a condenser C.

sponse at the low frequencies, may be jazzed up by means of the arrangement shown in Fig. 6. This is a resonant circuit composed of the condenser C and the iron-core choke CH. The bass boost should be in the vicinity of 100 cycles, and for this frequency C should have a value of .02 mfd, and CH a value of 500 henries. These values will be satisfactory for most applications.

### SHOW LITERATURE

(From page 24)

Auto Radio Guide. Has 128 pages, much useful information in addition to the listings. Supplementary information service included in price, which is 25 cents. The Radiart Corp., Cleveland, Ohio.

RCA—Characteristics Chart and Socket Connections of RCA Receiving Tubes. Includes a tube classification list. RCA Manufacturing Co., Inc., Camden, N. J.

Stancor—Service Guide and Replacement Transformer Catalog, 6th Edition. Contains listing of receiver models by manufacturer, with replacement type numbers for audio and power transformers, and filter chokes. Standard Transformer Corp., 1500 N. Halstead St., Chicago, Ill.

Utah—In 1940 Catalog—Vibrator Replacement Guide. Also cross index of same. Utah Radio Products Co., Chicago, Ill.

## Mr. Radio Serviceman:

# A NEW SEASON BEGINS — — MOVE FORWARD WITH RSA!

Plans announced at the Radio Parts Trade Show make it more imperative than ever that you belong to RSA. All the new developments planned by manufacturers place increased responsibility on trained top-flight servicemen. Join other good servicemen in RSA! Send the Coupon today!

**MAIL THIS COUPON NOW!**

RADIO SERVICEMEN OF AMERICA, INC.  
304 S. Dearborn St., Chicago, Ill.

Name .....

Address .....

City ..... State .....

I am interested in RSA Membership. Tell me about it .....

I am enclosing \$4.00 for National dues and initiation. Covers dues up to Jan. 1, 1941 .....

(Does not include Local Chapter dues where Local Chapters are organized.)

RS-740

Let's Grow Together

In 1940!



## RADIO SERVICEMEN OF AMERICA, Inc.

JOE MARTY, JR., EXECUTIVE SECRETARY  
304 S. DEARBORN STREET, CHICAGO, U.S.A.

# JACKSON

## Dynamic TUBE TESTERS



Model 636  
Only \$29.95

The most accurate Tube Tester you can possibly buy! Jackson's patented Dynamic circuit makes a better test—frequently finding "poor" tubes which might pass for "good" in ordinary testers. And because the Jackson Dynamic circuit is less complicated, quality instruments cost less.

### Dynamic ANALYZERS

Jackson's Dynamic signal testing is direct, positive. Measures the signal itself, tracing its path through the receiver to the exact point of the trouble.

### OSCILLATORS

Write for FREE Folder

Jackson Audio Oscillators operate on a new basic principle—audio frequency voltage is developed at its fundamental frequency. ASK YOUR JOBBER about JACKSON INSTRUMENTS.

THE JACKSON ELECTRICAL INSTRUMENT CO., Dayton, Ohio



## Dollars for YOU!



### DEALER PROFITS

Every smart radio dealer will write TODAY on his business letterhead for a copy of the new UNIVERSAL catalog and for full details on the new discount setup that enables every local Dealer to re-sell to local schools, churches, lodges, etc., and allow the buyer a discount, yet through the new UNIVERSAL setup, leaving a legitimate profit for the Dealer who is, as always, entitled to a fair profit for the service he renders.

**UNIVERSAL MICROPHONE CO., LTD.**

Inglewood, Calif., U. S. A.

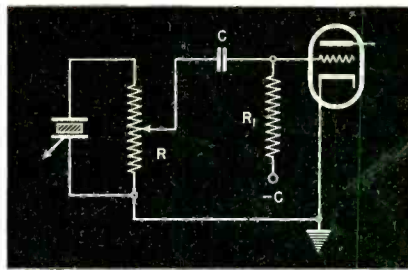

Fig. 3. Where there is an actual bias voltage on the tube grid, it should be isolated from the pickup by a blocking condenser, C.

ists on the grid—such as would be the case with a bias cell, with contact-potential bias, or a grid return to a source of negative voltage in the power supply—then it is important that a blocking condenser be inserted (if one is not already in the circuit) to keep the grid voltage off the pickup crystal element. It should be remembered that not only will pressure on a crystal unit develop a voltage, but also a voltage applied to the faces of a crystal will alter its shape. Hence, if the bias voltage for the a-f tube is permitted to appear across the crystal unit, the crystal will be under tension and the pickup needle thrown off its normal vertical axis.

The proper connections when this condition prevails, are shown in Fig. 3. Condenser C should have a capacity of .01 mfd or more.

### CORRECTION AND EQUALIZATION

Few crystal pickups give optimum results if they are merely hitched across the receiver volume control. Aside from the peak at the low end, one or more peaks exist at the high end which give rise to needle hiss and shrillness of tone. An ironing out of these peaks improves reproduction considerably.

As previously mentioned, the peak in the bass region may be reduced by decreasing the value of the load resistance. Peaks in the upper range can be reduced by the addition of a filter, as shown in Fig. 4. Generally speaking, the resistor R determines the degree of bypassing and the condenser C the frequency at which the greatest degree of bypass will occur. Typical values are 100,000 ohms for R and .02 mfd for C. The effect on frequency of condenser C1 is small if its

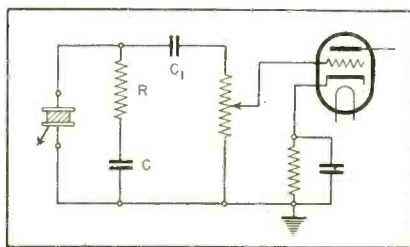

Fig. 4. Circuit for reducing peaks in the upper range of a crystal pickup.

Only WARD can give you these features

## Flex-Angle

Patent Applied For



### THE AERIAL THAT FITS ALL COWL CONTOURS WITHOUT CONVERSION PARTS

One mounting, with 16° adjustment, adapts it to Torpedo or Chrysler bodies. 3-section aerial, 68" lists at \$3.35.

### Ceramic Stanchions

Three section aerials (5XXL, 66" and 8XL, 93") and four section aerials (151L, 100") are available with Ceramic low-loss Stanchions.

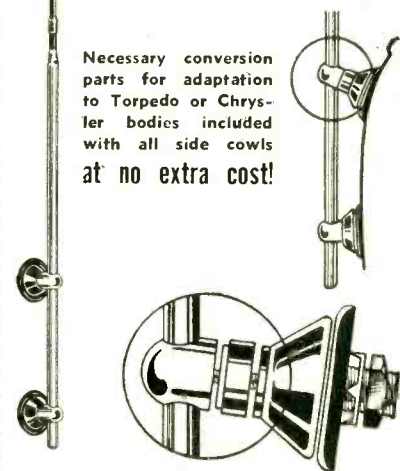

Send for complete catalog

The WARD PRODUCTS CORP.

WARD BUILDING CLEVELAND, OHIO

## The RIGHT Product . .

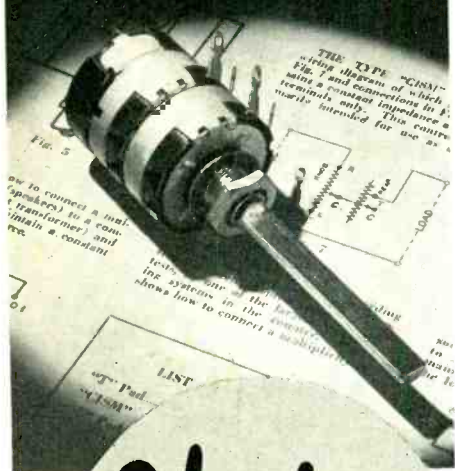

Plus  
The RIGHT  
DATA

- ★ Successful servicemen everywhere are turning more and more to Clarostat controls these days, for two very obvious reasons:

### The Right PRODUCT . . .

- ★ Two decades of pioneering and specialization can't go unnoticed. Clarostat controls are carefully engineered and made. They are precisely fitted to intended applications. Exclusive refinements insure the better-than-expected kind of service from such components. The serviceman can be sure he is using the best controls money can buy.

### The Right DATA . . .

- ★ Meanwhile, to make certain that the right type control will be used, Clarostat provides the most extensive, up-to-the-minute listings of control requirements of all standard receivers in use. The Clarostat Service Manual has become the guide of those servicemen known for the quality of their jobs. It is this close partnership of THE RIGHT PRODUCT AND THE RIGHT DATA which spells THE RIGHT JOB, the Clarostat way.

### Ask for MANUAL . . .

- ★ Local jobber has your copy of the Clarostat Service Manual covering control replacements. Ask for it—it's free. Also copy of Plug-In Resistor Replacement Manual for 15c to cover cost of limited edition. Or write us direct.

**CLAROSTAT MFG. CO., Inc.**  
Dept. 51, 285 N. 6th St. Brooklyn, N. Y.



attached a tiny mirror. The combined stylus and mirror has low mass and stiffness, with the result that the stylus practically floats in the record groove. This low stylus pressure and flexibility of motion reduce record wear to a negligible point. The light source is an argon tube energized by a vacuum-tube oscillator operating at a high radio frequency. The light variations caused by the vibration of the mirror are impressed on the photo-electric cell which is mounted in the pickup arm.

Less expensive and complex, and of equal merit from the viewpoint of stylus and record wear, and the response that can be taken off a commercial record, are the Astatic and Brush permanent sapphire stylus, low pressure pickups with torque wire coupling. They'll preserve commercial records through their useful life, which is between five and ten years, after which they become tonally obsolescent due to technological advancements in recording practice.

### PHONO SERVICING

(From page 5)

change in the setting of the volume-control arm. It is purely a form of compensated volume control having proportionately greater bass response at low settings and increasingly less bass response as the volume control is increased. The advantage of this arrangement lies in the fact that phonograph motor rumble and growl are usually not noticeable at low volume settings; hence, bass response need not be attenuated in this low-volume region. As the control is advanced, which would ordinarily bring up the rumble, the bass response is progressively reduced.

In cases where rumble is very difficult to eliminate, look for cabinet resonance. The only solution in such an instance is to line the interior of the cabinet with sound-absorbing material, or, where the speaker compartment is separate from the chassis, and no ventilation problems exist, to form an infinite baffle of the speaker compartment.

### PICKUP INSTALLATION

The addition of a record player to a radio receiver is a simple enough procedure, and no diagrams are called for. However, it is important to determine the characteristics of the input circuit of the first amplifier stage before tying in the pickup. So long as the grid of the a-f tube is biased by means of a cathode resistor, the pickup may be tied directly to the grid or the high end of the receiver volume control.

However, if this tube is biased in such a manner that an actual voltage ex-

# IF

You Are NOT a  
PAID Subscriber  
to

Radio  
**SERVICE  
DEALER**

You May NOT Receive  
The Next Few Issues

You Can't Afford To  
Miss A Single Copy

**SUBSCRIBE TODAY**

(Use coupon on page 22 of this issue)

## NEW Combination TESTER

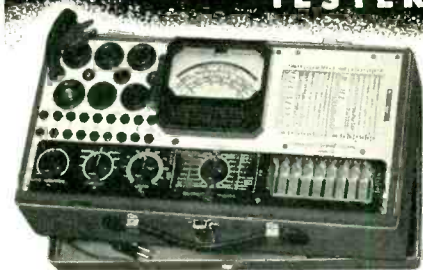

**TRIPLET**

Model 1183

**\$49.84**

Dealer Net Price

Volt-Ohm-Milliammeter, Tube Tester and Free Point Tester

Model 1183 is truly a Non-Obsolescent Tube Tester, combined with a Volt-Ohm-Milliammeter and Free Point Tester . . . three fundamental testers in one handy case . . . a tester you can use for many years. Volt-Ohm-Milliammeter Ranges: AC-DC Volts 0-10-50-250-500-1000; DC at 10,000 ohms per volt, AC at 2000 ohms per volt; DC Milliampers 0-1-10-50-250; Resistance 0-500 low ohms; 0-150,000 Ohms; 0-1.5 and 0-15 Megohms. Complete Free Point Tester with sockets for all tubes, including new Miniatures. Tube Tester has new lever type switch section with individual control for each tube element. Speedex Roll Chart, removable from panel as separate unit. . . Dealer Net Price . . . \$49.84.

Write for Catalog—Section 477 Harmon Drive

**THE TRIPLET ELECTRICAL INSTRUMENT CO.**  
Bluffton, Ohio

## SERVICEMAN'S DIARY

(From page 7)

indoor affair. I did manage to get a faint response, but the kid said it had worked better before. Nothing much that I could do, other than to suggest he get another crystal.

Back to the shop to fix up a Crosley job which came in last night, and to relieve Jerry so he could go to lunch. And to get ready the p-a amplifier for rental over at the hot spot on the main drag, but I'll get that down on paper later. Bye, bye until tomorrow.

## CIRCUIT COURT

(From page 10)

Therefore, so long as the receiver is not plugged in to a 110-volt circuit, the receiver will operate from the battery pack when turned on, for the right-hand relay contacts close the A plus and B minus battery leads.

If the receiver is plugged in to a 110-volt circuit, and turned on, it will operate on the batteries until the 117Z6GT warms up and passes sufficient current through the solenoid to trip the relay, at which time the right-hand contacts open and disconnect the A and B batteries from the tube circuits. When the relay trips there is no decrease or dead spot in the output, as the rectifier is warmed up sufficiently to carry the load and give a slight increase in output due to the higher plate voltage available.

The rectified voltage for the filament string is filtered by the 7.5-watt, 110-volt lamp, *L*, which; 1) regulates the voltage, 2) acts as a filter and, 3) as an On-Off indicator. The remainder of the filter is composed of the resistor *R1*, the relay solenoid which functions as a choke, and the associated filter condensers, *C1*, *C3* and *C4*. The resistors *R2* and *R3* in the filament circuit function as plate-current compensators. The rectified B supply is filtered by resistor *R* and condenser *C2*.

**Caution:** The relay is insulated from the chassis and care should be taken when probing so as not to short it.

## SHOW REVIEW

(From page 6)

Now that the field knows where it stands on f. m., what frequencies have been assigned for this service, and the number of probable transmitter outlets, receiver production will be in full swing in short order.

With regard to home recording, most manufacturers of phono-radio-recorders have resorted to the use of a more or less standard unit, with crystal cutter,

crystal pickup, and simple under-chassis feed mechanism. This is a break for the serviceman.

Introduced at the show was a portable paging system, comprising a battery-operated amplifier, microphone and shoulder strap. It was used for making special announcements throughout the exhibition area and proved highly successful. The system used will soon be placed on the market.

The trend in servicing is very definitely toward high-impedance test and measuring equipment, given impetus by the

introduction of signal-tracing devices. A number of new vacuum-tube voltmeters have been introduced which have considerable flexibility, wide adaptability and increased scope. There have also appeared a number of improved non-obsolete tube testers, battery testers, and signal generators with greater frequency range and stability.

## PICKUPS

Philco demonstrated their photo-electric phonograph pickup, which consists of a permanent sapphire stylus (with a purported life of 11 years) to which is

**RADIO'S**  
**FINEST Electronic VOLT METER**



\$39<sup>95</sup>

**Dealer Net Cash Price**  
**S.I.C. Time Payment Plan**  
**\$5.00 cash and 10 monthly**  
**payments of \$3.90.**

In Metal Case

MODEL 549

ELECTRONIC VOLT METER

Model 549 is the result of a long period of research in designing a multimeter which will fulfill the serviceman's needs of today and tomorrow at a price he can afford to pay. The instrument will take care of all the serviceman's multimeter requirements since it has standard provisions for A.C. and output volts, direct current measurements, etc., in addition to the electronic circuit for D.C. voltage and resistance measurements.

**0.1 TO 6000 D.C. VOLTS**—covered by six overlapping ranges of 0/2/6/20/60/200/600 volts. These ranges may be extended to 6000 volts, at small extra cost, by use of a SUPREME Type 4875 Probe. The input impedance of all ranges up to and including the 600 volt range is 15,000,000 ohms. The input impedance of the 6000 volt range is 150,000,000 ohms. Both probes for measuring D.C. volts have a built-in resistance so that the D.C. volts developed across oscillator grid leak can be measured without materially affecting the oscillator. Also all plate, screen bias, A.V.C., and A.F.C. voltages can be measured without upsetting the operation of the receiver. Voltages of either negative or positive polarity with respect to chassis or ground may be measured by setting the circuit selector switch to “-” volts or “+” volts. The low range of 2 volt full scale gives a sensitive meter necessary in measuring small control voltages.

**0.5 OHMS TO 1000 MEGOHMS**—covered by 5 overlapping ranges of 0/1000/100,000/1 megohm/10 megohms/1000 megohms. This electronic circuit permits all resistance ranges, including the 1000 megohm range, to be operated by the self-contained 3 volt bat-

tery. Features incorporated are the extreme accuracy acquired by adjusting the ohmmeter at “zero” position and “full scale” position. After this is once set there are no adjustments to be made between ranges. The low range has a center scale resistance of fifteen (15) ohms which gives a good deflection in checking resistances of radio frequency coils. You will like this type of ohmmeter for its speed and accuracy. Being of an electronic type the meter is fully protected and accidental application of the voltage to the ohmmeter will not injure the instrument.

**0.1 VOLT TO 500 A.C. VOLTS**—covered by 5 overlapping ranges of 0/5/15/50/150/500 volts in a circuit whose calibration is guaranteed to  $\pm 3\%$ . Copper oxide rectifier is fully protected and carries the same guarantee as all other parts in the instrument. Temperature error of rectifier is corrected over a working range of 40° F to 100° F.

**10 MICROAMPERES TO 15 AMPERES D.C. CURRENT**—covered by 7 direct ranges of 0/500 microamperes; 0/5/15/50/150/500 M.A.; and 0/15 amperes. Such a wide selection of ranges was incorporated to meet all current measurements necessary—from the few microamperes found in control circuits to the ampere drain of automobile receivers.

**0.1 TO 500 OUTPUT VOLTS**—can be used with any good signal generator (SUPREME Model 571 or 561) for receiver alignment. Covered by five ranges of 0/5/15/50/150/500 Volts.

The Model 549 is also available in beautiful oak case as illustrated for \$42.50 cash or \$5.00 cash and 10 monthly payments of \$4.18.

SUPREME

SUPREME INSTRUMENTS CORP.  
GREENWOOD, MISSISSIPPI, U.S.A.

SEND FOR NEW CATALOG

—just off the press. Large, two color illustrations, complete descriptions of 22 new 1941 model SUPREME quality testing instruments. Write today!

placement speakers of e-d and p-m types. Oxford-Tartak Radio Corp., 915 W. Van Buren St., Chicago, Ill.

**Park Metalware**—Catalog sheet on new XceLite combination Phillips screwdriver and standard screwdriver in one unit. Park Metalware Co., Inc., Orchard Park, N. Y.

**Pioneer**—Catalog No. HC-4-40 on Pioneer Rotary Converters for every purpose. Pioneer Gen-E-Motor Corp., 466 W. Superior St., Chicago, Ill.

**Precision**—Test Equipment Catalog covering dynamic tube testers, multimeters, set testers, and signal generators. Precision Apparatus Co., 647 Kent Ave., Brooklyn, N. Y.

**Radiart**—Bulletin on auto and home receiver aerials. Bulletin on exact-duplicate vibrator units. Includes replacement list. The Radiart Corp., Cleveland, Ohio.

**Rider**—Four-page folder "Shedding Light on Radio", on the latest Rider books. Bulletin sheet on Rider's Manual, Volume XI, just released. John F. Rider, Publisher, Inc., 404 Fourth Ave., New York, N. Y.

**Simpson**—Catalog No. 11 on Panel and Switchboard Instruments—meters of all types. Catalog No. 12 on Radio and Television Test Equipment and Panel Meters, including tube testers, set testers, signal generators. Additional catalog on Simpson "Micro-Testers," for laboratories, servicing and production testing. Specifications on twelve units. Simpson Electric Co., 5216 Kinzie St., Chicago, Ill.

**Solar**—Catalog 10 on all types of capacitors for radio and television. 32 pages. Also sales leaflets on Red Caps and Solar Condenser Quick-Check units. Solar Manufacturing Corp., Bayonne, N. J.

**Sprague**—1940 Condenser Retail Catalog of 20 pages. Covers all types of electrolytics, fixed micas, trimmers, and replacements. Also bulletin on Koolohm Resistors. Sprague Products Co., North Adams, Mass.

**Supreme**—Catalog of Radio Testing Instruments, including visual and aural dynamic testers, service oscillators, oscilloscopes, tube and set testers, etc. Supreme Instruments Corp., Greenwood, Miss.

**Televiso**—New catalog on Televiso measuring and servicing equipment, including Model VC-11 Decibelometer. Televiso Products, Inc., 1135 N. Cicero Ave., Chicago, Ill.

**Thordarson**—Catalog No. 400-E covering complete line of audio and power transformers. Catalog No. 500-E, specifications and prices on "Tru-Fidelity" Broadcast Transformers. Catalog No. 600-E gives complete dope on the Thordarson line of amplifiers, microphone cable transformers, and carrying cases. Thordarson Electric Mfg. Co., 500 West Huron St., Chicago, Ill.

**Transformer Corp.**—Catalog No. 150 on the Clarion line of sound systems, intercommunicators, record players, microphones, speakers, etc. Transformer Corp. of America, 69 Wooster St., New York, N. Y.

**Triplet**—1941 catalog covers new tube testers, volt-ohm-milliammeters, signal generators, dry-battery tester, set and vibrator testers, vacuum-tube voltmeters, etc. Also the eight "Little Triplets"—a series of matched instruments available in single units. The Triplet Electrical Instrument Co., Bluffton, Ohio.

**Triumph**—Catalog sheets on Model 444 Tube Tester, the "Percent-O-Meter" radio battery tester, Model 334 Multirange Meter and Model 130 Signal Generator. Triumph Mfg. Co., 4017 West Lake St., Chicago, Ill.

**United Teletone**—Bulletin No. S.P. 40 covering complete line of Cinaudagraph Speakers. United Teletone Corp., 150 Varick St., New York, N. Y.

**United Transformer**—Bulletin PS-404 listing complete line of audio and power transformers for general radio use. Includes schematics, with parts values, of typical amplifiers for various purposes. Bulletin No. BC-1 covers quality transformers for broadcast and commercial service. Also contains amplifier schematics. United Transformer Corp., 150 Varick St., New York, N. Y.

**Utah**—1940 catalog of Utah speakers, vibrators and transformers, and Utah-Carter replacement controls, attenuators, resistors, jacks and plugs. Catalog contains replacement vibrator guide. Utah Radio Products Co., Chicago, Ill.

**Walsco**—Catalog No. 41 on "Products for the Radio Man", including the new Walsco Staple Driver for radio and electrical installation work; and the Walsco Radio Cabinet Patching Outfit. Walter L. Schott Co., 5264 W. Pico Blvd., Los Angeles, Calif.

**Ward**—Catalog No. WA-6 on "Ward Banner Line for '40-'41" of antennas for all services, including those for television and frequency modulation. Also booster units for auto antennas. The Ward Products Corp., Ward Building, Cleveland, Ohio.

**Webster Electric**—Bulletin RC-143:—Series 80 and 82 Crystal Pickups. Bulletin RC-144:—Crystal Pickup Cartridges. Bulletin RC-145:—R-83 and R-84 Magnetic Recorder Cutting Heads for professional and home use. Webster Elec. Co., Racine, Wis.

**Weston**—Bulletin on Model 787 Ultra-High-Frequency Oscillator for television and frequency modulation alignment work. Bulletin covering Multi-Range, Multi-Purpose Test Instruments for Industry, Laboratory and School. Bulletin "Ideas for Profitable Servicing." Includes specifications on tube and battery checker, vacuum-tube voltmeter, test oscillator, Checkmaster, Serviset, and Type 2 Analyzer. Weston Electrical Instrument Corp., Newark, N. J.

**SERVICING AIDS**

**ATR**—Replacement Vibrator Guide for auto-radio and battery-operated household receivers. Receiver models listed alphabetically by manufacturer; cross-reference list by vibrator type number. Vibrator specifications and base diagrams included. American Television & Radio Co., St. Paul, Minn.

**Burgess**—Portable Battery Replacement Guide, covering portable and farm radios. Receiver models listed alphabetically by manufacturer.

Battery Replacement Guide for Radio Test Instruments. Alphabetical listing. Burgess Battery Co., Freeport, Ill.

**Carron**—Replacement Guides, with alphabetical listings, covering speaker cones, field coils, r-f, i-f and oscillator coils. Carron Mfg. Co., 415 South Aberdeen St., Chicago, Ill.

**Hygrade Sylvania**—New radio tube base chart. For the 376 types extant, there are shown 118 views and a complete index and cross index for all tubes and base views.

Also Sylvania booklet of tube characteristics. Hygrade Sylvania Corp., Emporium, Pa.

**IRC**—Volume Control Guide and Resistor Catalog, Edition No. 2, and 1940 Supplement to Volume Control Guide. Receiver models listed alphabetically by manufacturers' names. Also a numerical listing of control types. International Resistance Co., 401 N. Broad St., Philadelphia, Pa.

**Mallory**—Mallory-Yaxley Radio Service Encyclopedia, 3rd Edition, with Supplemental Technical Service. List price of Encyclopedia, \$1.25, monthly Supplement Service included. P. R. Mallory & Co., Inc., Indianapolis, Ind.

**Meissner**—Meissner Vibrator Replacement Guide. Includes general listing and cross index, buffer condenser replacement chart, and chart of equivalent units by manufacturers' numbers. Meissner Manufacturing Co., Mt. Carmel, Ill.

**National Carbon**—Brochure, "The ABC of Radio Battery Life"—how long the various types of batteries will last in 1.4-volt and 2-volt receivers.

Also, Replacement Battery Guide for Portable Receivers. Alphabetical listing. National Carbon Co., Inc., New York, N. Y.

**Permo**—"Permo Pointers on Better Recordings"—gives data on how to record different musical instruments, where to place mike, etc. Includes chart showing frequency range of various musical instruments compared to a piano keyboard. Permo Products Corp., 6415 Ravenswood Ave., Chicago, Ill.

**Radiart**—Radiart Vibrator Replacement List. Includes base diagrams and specifications.

Also, Radiart Vibrator Manual and

(Turn to page 28)

# SHOW LITERATURE FOR THE SERVICEMAN

## CATALOGS - BULLETINS

- Aerovox**—1939-40 Catalog of condensers, resistors, test instruments. Also 4-page bulletin on Aerovox Capacity and Resistance Bridge. Aerovox Corp., New Bedford, Mass.
- ♦
- American**—Catalog sheets on Directional Variable-Response Dynamic Microphone Type VR2, and new Moving Coil Dynamic Microphone Type D4T. American Microphone Co., Inc., 1915 S. Western Ave., Los Angeles, Calif.
- ♦
- ATR**—Catalog No. 139 covering vibrators, vibrator-operated and rectifier power supplies, and inverters. American Television & Radio Co., St. Paul, Minn.
- ♦
- Amperite**—Bulletin on new Pressure Gradient Dynamic Microphone and other units. Amperite Co., 561 Broadway, New York, N. Y.
- ♦
- Astatic**—Catalog No. 40 on Microphones and Phonograph Pickups. Includes data on new low-pressure pickups with permanent sapphire styli. Astatic Microphone Laboratory, Inc., Youngstown, Ohio.
- ♦
- Atlas**—Catalog F-40 covering loudspeakers, speaker horns, mike stands and mike accessories. Atlas Sound Corp., 1443 39th St., Brooklyn, N. Y.
- ♦
- Audio Devices**—Bulletin on "Audi discs", instantaneous recording blanks. Folder on the Audi disc "Chip Chaser"—a wiper for handling the thread from a blank while recording. Audio Devices, Inc., 1600 Broadway, New York, N. Y.
- ♦
- Belden**—Catalog 840. "Clear Channel" Antenna System, power-line filters, aerial and hookup wire, transmission line cables, shielded leads, etc. Belden Manufacturing Co., Chicago, Ill.
- ♦
- Bell**—Bulletin No. 33, 16 pages, covering amplifiers, p-a units, intercommunicators, crystal recorders, paging units. Bell Sound Systems, Inc., 1183 Essex Ave., Columbus, Ohio.
- ♦
- Bogen**—Catalog P-10, "The Blue Book of Sound Equipment," covering p-a systems, recording equipment, record players, speakers and microphones. David Bogen Co., Inc., 663 Broadway, New York, N. Y.
- ♦
- Bud**—General Catalog No. 240 of radio parts and kits, with 40 pages. Bud Radio, Inc., Cleveland, Ohio.
- ♦
- Carron**—1940 Catalog of Replacement Parts, such as speaker cones, voice coils, field coils, r-f and i-f transformers, coil kits. Also catalog sheet on new Carron Signal Tracing Amplifier Model CCH. Carron Manufacturing Co., 415 S. Aberdeen St., Chicago, Ill.
- ♦
- Challenger**—4-page bulletin on Challenger amplifier and p-a systems. Challenger Amplifier Co., 230 Mercer St., New York, N. Y.
- ♦
- Continental**—6-page bulletin on condensers, resistors, suppressors, and noise filters. Continental Carbon, Inc., 13900 Lorain Ave., Cleveland, Ohio.
- ♦
- Eby**—New catalog with supplement sheets covering selector switches, sockets and connectors, plugs, binding posts, battery harness, knobs, and electric eye kits and units. Hugh H. Eby, Inc., 4700 Stenton Ave., Philadelphia, Pa.
- ♦
- Electro-Voice**—4-page bulletin on dynamic mikes, velocity mikes, matching transformers, mike accessories. Electro-Voice Mfg. Co., Inc., 1239 South Bend Ave., South Bend, Ind.
- ♦
- Electrovox**—Folder on new Walco home recording discs, sapphire cutting and playback needles. Electrovox Co., 424 Madison Ave., New York, N. Y.
- ♦
- Esico**—New catalog folder on Esico soldering irons, soldering iron controls, solder pots, and soldering machines. Electric Soldering Iron Co., Inc., Deep River, Conn.
- ♦
- General Cement**—Catalog No. 141 covering radio chemicals and products, such as, speaker cements, solvents, varnishes, coil dopes, cleaners, dial drive cables, belts and rubbers. General Cement Mfg. Co., Rockford, Ill.
- ♦
- General Industries**—Folder on phonograph motors, record changers and home recording assemblies. The General Industries Co., Elyria, Ohio.
- ♦
- General Transformer**—Bulletin on new GTC Porta-Power units for electrifying battery radios of all types. General Transformer Corp., 1254 W. Van Buren St., Chicago, Ill.
- ♦
- Guardian**—Bulletin No. R-A on antenna, keying, underload, overload, break-in and high-frequency relays. Guardian Electric Mfg. Co., 1621 W. Walnut St., Chicago, Ill.
- ♦
- Howard**—Bulletin on new Howard instantaneous recording blanks. Howard Radio Co., 1735 W. Belmont Ave., Chicago, Ill.
- ♦
- Insuline**—Catalog 207 of radio parts and accessories. 42 pages. Insuline Corp. of America, 30-30 Northern Blvd., Long Island City, N. Y.
- ♦
- IRC**—Catalog No. 45 covering volume controls, insulated resistors, wire-wound power resistors, attenuators, suppressors, etc. International Resistance Co., 401 N. Broad St., Philadelphia, Pa.
- ♦
- Jackson**—1941 Catalog of Testing Equipment, covering tube testers, test oscillator, dynamic signal analyzer, audio oscillator, oscillograph, service laboratory units, etc. The Jackson Electrical Instrument Co., Dayton, Ohio.
- ♦
- JFD**—1940 catalog of radio accessories and replacement parts, such as, control shafting, auto antennas, antenna lead cables, radio dial belts, ac-dc ballasts and line cords, phono pickup coils and dampers, speaker shims, etc. J.F.D. Manufacturing Co., 4111 Ft. Hamilton Parkway, Brooklyn, N. Y.
- ♦
- Mallory**—1940 Catalog of Approved Precision Products, covering the Mallory-Yaakley line of replacement controls, selector switches, jacks and plugs, fixed and adjustable resistors, electrolytic condensers, vibrators, vibrator power supplies, etc. 40 pages. P. R. Mallory & Co., Inc., Indianapolis, Ind.
- ♦
- Meck**—Bulletin of 4 pages on Audiograph Sound Systems. John Meck Industries, 1313 W. Randolph St., Chicago, Ill.
- ♦
- Meissner**—1939-1940 Confidential Net Price Catalog, 48 pages. Latest Meissner receivers, receiver kits, new amateur devices, r-f and i-f transformers, variable and adjustable condensers, etc. Meissner Manufacturing Co., Mt. Carmel, Ill.
- ♦
- Million**—Catalog No. 39 of Modern Test Equipment, including signal generators, tube checkers, multimeters, vacuum-tube voltmeters, signalizers and sound systems. Million Radio & Television, 685 W. Ohio St., Chicago, Ill.
- ♦
- National Carbon**—Catalog No. C-1276 covering dry-cell A, B and C batteries, and Air Cell A batteries. National Carbon Co., Inc., New York, N. Y.
- ♦
- Ohmite**—Catalog No. 40 covering resistors, rheostats, attenuators, tap switches. Ring binding, 96 pages, sectional guides. Contains dimension drawings, and helpful engineering information. Ohmite Manufacturing Co., 4835 W. Flournoy St., Chicago, Ill.
- ♦
- Oxford**—Bulletin No. 400 on p-a and re-

# Hurry Hurry Hurry!

## YOU CAN STILL SAVE \$1.00

Subscribe to **RADIO SERVICE-DEALER NOW** while the *Introductory Half-Price Rate* is still in effect. **12** informative issues of RSD—crammed full of exclusive technical data that will help you do your work more efficiently, in less time, at greater profit.

### THANK YOUR JOBBER

Every Service-Dealer who received this copy of R.S.D. thru the mails was selected by a Jobber who believed him to be the outstanding servicer in his particular community. Each copy costs nearly 25c to put on a reader's desk. Subscriptions are accepted from only the industry's best Service-Dealers and Soundmen . . . men like yourself who were qualified by Jobbers.

### INTRODUCTORY RATES STILL IN EFFECT

The *introductory* \$1.00 subscription rates (half of our regular rate of \$2.00 for 12 issues) **WILL NOT BE IN EFFECT LONG . . .** nor will you receive copies of R.S.D. without charge every month. The only way to insure you of receiving the next 12 issues of R.S.D. is to **SUBSCRIBE TODAY**. Remember, \$1.00 for 12 issues—\$2.00 for 24 issues **IF YOU SUBSCRIBE NOW** and are accepted as a bona-fide, qualified Service-Dealer.

\* No subscriptions are accepted without complete data as to your status in the field thus entitling you to the half-price subscription rate. Use coupon below. (Annual subscriptions from a very limited number of part-time, qualified servicemen or students enrolled in accredited schools with radio courses will be accepted at \$2.00 each for 12 issues of R.S.D. at the Publisher's option.)

**Regular Annual Subscription Price for 12 Issues of Service-Dealer is \$2** (FOREIGN \$4)

**TEAR OUT AND MAIL TODAY!**

**THIS COUPON AND \$1.00 BRINGS 12 ISSUES OF RSD TO YOU!**

RADIO SERVICE DEALER, SOUNDMAN & JOBBER  
11 West 42nd Street, New York, N. Y.

Sirs: Enclosed herewith is my  check (or  money order) for \$ . . . Please enter my annual subscription order (12 issues) at \$1.00 for 1 year or \$2.00 for 2 years, (24 issues)— $\frac{1}{2}$  the regular price. Foreign subscriptions are \$2.00 yearly. I believe the information given below is accurate. **IF MY SUBSCRIPTION IS REJECTED I EXPECT TO RECEIVE IMMEDIATELY A REFUND IN FULL FOR THE AMOUNT ENCLOSED.**

NAME (print carefully) .....  
ADDRESS .....  
CITY ..... STATE .....  
FIRM NAME ..... Est. 19.....  
YOUR POSITION .....

*Please check whether firm is*

- An independent servicing organization
- An independent service-dealer (engaged primarily in service work)
- A service-dealer (does servicing, but is primarily interested in retailing)
- Selling, renting or servicing Sound Equipment
- Jobber  any other classification, (state it) .....
- Manufacturer

I belong to a serviceman's organization . . . Yes  . . . No

My Jobbers are (name) .....

**PLEASE SEND ME . . . . . ADDITIONAL SUBSCRIPTION BLANKS**

*We stock the following checked items:*

- TUBES
- PARTS
- RECEIVERS
- BATTERIES, etc.
- SOUND EQUIP.
- ELEC. APP'L'S.

*We own the following Instruments:*

- V-T Voltmeter
- Tube Checker
- Analyzer
- Oscillator
- Signal Generator
- Volt-Ohm Meter
- Others
- MANUALS

## Trade Showings



indicates its condition. Inherent regulation compensates for line-voltage fluctuations. Operation is simple and speedy as only two controls are necessary. By Radio Service Engineers, 110 W. Packard Ave., Ft. Wayne, Ind. RADIO SERVICE-DEALER.

### SIMPSON

**Tube Tester**—Model 400 "Professional Standard" has three sections—the socket panel, the meter panel with controls, and the roll chart panel. The roll chart and the socket panel are designed as separate units and can be removed without disturbing the meter. The tester can be kept up-to-date by the installation of new socket and roll panels, whereupon the old panels can be returned to the manufacturer for credit.

The new 3-way switching system includes an off position for each switch so that any tube prong can be left disconnected from any part of the tube testing circuit, thus allowing the testing of the individual elements of every tube regardless of base connections or the internal connections between the elements.

Two spare sockets are provided for future tube developments and the panel itself made oversize so more sockets may be added. A "write-it" window makes it possible to add data on new tubes to the roll chart. By Simpson Electric Co., 5216 Kinzie St., Chicago, Ill. RADIO SERVICE-DEALER.

### SOUND APPARATUS

**Dynamic Cutter**—A dynamic cutting head for lateral recording, with a frequency range extending to 9000 cycles. Driving power, 1 watt. Weight of head, 7 ounces. Impedance is 6 ohms.

Air damping is employed; not subject to changes of temperature. By Sound Apparatus Co., 150 West 46th St., New York, N. Y. RADIO SERVICE-DEALER.

### SPRAGUE PRODUCTS

**Koolohm Resistors**—Wire uniformly insulated with hard, moisture-proof insulation which conducts heat away from wire with such rapidity that wire is not damaged by red heat. The insulation also makes possible interleaved windings with accuracy of 5 percent or better, zero inductance at 50 mc and distributed capacity of only 2 mmfd.

Koolohms have Teledot Wattage Indicators and are available in 5-watt fixed types; 10-watt fixed; 10-watt adjustable and 10-

watt non-inductive. By Sprague Products Co., North Adams, Mass. RADIO SERVICE-DEALER.

**DeLuxe Tel-Ohmike**—This model condenser and resistor analyzer includes built-in voltmeter and milliammeter with switch and pin jacks provided so that meters may be used for external measurements.

Meter ranges, selected through an 8-position switch, are 15, 150, 500, 1500 volts d.c., and 1.5, 15 and 50 ma d.c.

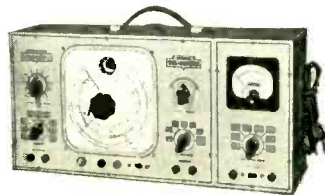

In other respects, the DeLuxe Tel-Ohmike is the same as the standard model. Both by Sprague Products Co., North Adams, Mass. RADIO SERVICE-DEALER.

### SUPREME

**Model 549 Electronic Voltmeter**—Has standard provisions for a-c and output volts, d-c measurements, etc., in addition to electronic circuit for d-c voltage and resistance measurements. Obtainable in metal case, without lid, for shop use, or quartered oak case with removable cover with space for test leads, etc.

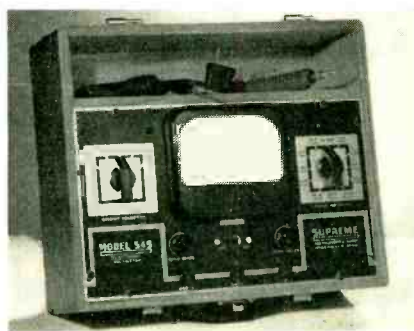

**D-C Voltage**—Covered in six ranges of 0/2/6/20/60/200/600, with extension to 6000 by use of special probe. Input impedance to 600 v. is 15 megohms; at 600 v., 150 megohms.

**Resistance**—Covered in five ranges of 0/1000/100,000/1 meg/10 megohms/1000 megohms. Electronic circuit allows 1000-meg range to be reached with 3-volt battery.

**A-C Volts**—Covered in five ranges of 0/5/15/50/150/500 with circuit calibration of  $\pm 3\%$ . Copper oxide rectifier used.

**D-C Current**—Covered in seven ranges of 0/500 microamperes; 0/5/15/50/150/500 ma, and 0/15 amps.

**Output Volts**—Covered in five ranges of 0/5/15/50/150/500.

By Supreme Instruments Corp., Greenwood, Miss. RADIO SERVICE-DEALER.

### TRIPLETT

**Tube Tester**—Model 1620, for 110 volts, 60 cycles, has highly flexible switching system, 6-inch scale red-dot lifetime guaranteed indicating instrument, and anti-obsolence design.

Anti-obsolence is introduced by providing four separate panel sections—socket, meter, roll chart, switching and power supply—which can be entirely replaced at nominal cost with a trade-in allowance for each old section dispensed with.



New, lever-type flexible switching gives individual control for each tube prong. This also takes care of roaming elements, dual cathode structures, multi-purpose tubes, etc. By The Triplett Electrical Instrument Co., Bluffton, Ohio. RADIO SERVICE-DEALER.

### WEBSTER-CHICAGO

**60-Watt Amplifier**—Webster-Chicago announces the addition of the W-860 amplifier to their standard line. The unit, housed in a modern wrinkle finish case, incorporates such features as electronic mixing of two high-gain microphone inputs, multi stage inverse feedback, voice coil and line impedance outputs, no-glare illuminated glass panel and locking type input plugs. The amplifier, conservatively rated at 60 watts, utilizes four 6L6 beam-power output tubes with a 6X5 rectifier tube for bias—flat from 50 to 10,000 cycles and with a gain of 125 db it is an ideal high-power amplifier for large auditoriums and outdoor installations. RADIO SERVICE-DEALER.





## Trade Showings

testing, and a meter showing percentage of useful life.

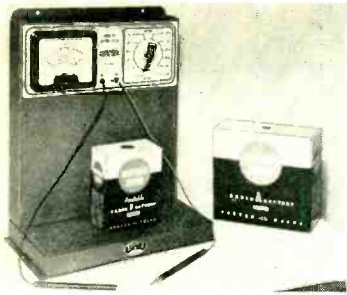

Finished in two-tone brown with red switching knob. Full information from National Union Radio Corp., 57 State St., Newark, N. J. RADIO SERVICE-DEALER.

### OHMITE

**Power Rheostat**—Model T has 750-watt rating, is 10" in diameter, with a  $\frac{3}{8}$ " shaft. Mounts on panels up to 1 $\frac{1}{4}$ " thick. Wire is wound on solid porcelain core and insulated by vitreous enamel. The shaft

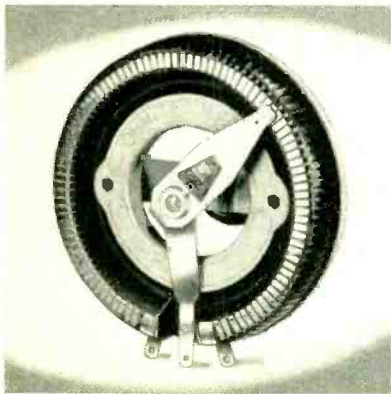

and mounting are insulated from all live parts. Large copper graphite contacts are used for long life and negligible contact resistance. By Ohmite Manufacturing Co., 4835 Flournoy St., Chicago, Ill. RADIO SERVICE-DEALER.

### OPERADIO

**Intercommunication Systems**—One type consists of Model 420-12 Master Station (illustrated) and Model Z Speaker Stations. Type BH is a combination paging and intercommunication system.

Features are: conference hookup, two-

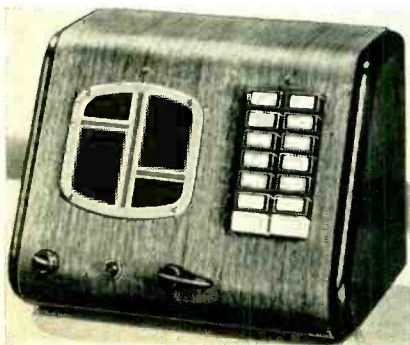

way conversation with all speaker stations, unlimited number of stations, no cross-talk, new push-type station-selector switches, flexibility of use and installation, combination paging and intercommunication feature, speaker "call switch."

Designed for 110 volts a.c. or d.c. Booster amplifiers available for paging service. By Operadio Mfg. Co., St. Charles, Ill. RADIO SERVICE-DEALER.

### PIONEER

**Power Plant**—Pioneer Gen-E-Motor Corporation, 466 West Superior Street, Chicago, has developed a new five kilowatt power plant.

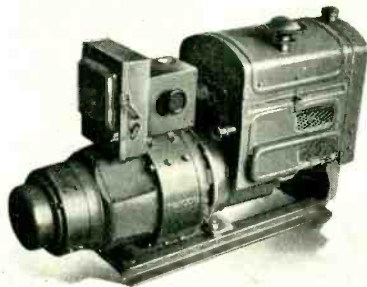

The engine on this new Pincor Gold Crown is completely enclosed in a sheet metal housing to protect it against the elements, dirt, etc. It is conservatively rated, which makes for long life and efficient operation. A four-pole generator is employed—1800 r.p.m. It is of the single, grease sealed ball-bearing type. Rheostat, voltmeter and switchbox are standard equipment. Filter and shielding available for radio operation. Remote control and other accessories also available. RADIO SERVICE-DEALER.

### RACON

**Ball Speaker**—A new ball-type cone speaker to be used where directional sound is required and where the standard type of cone projections clash with the surrounding

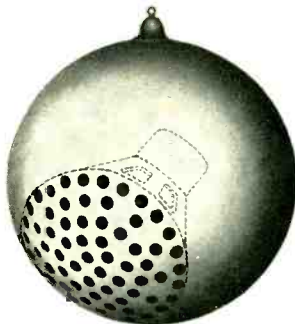

furnishings or architecture. Projects a beam at 45 degrees. Operates with 6", 8" and 10" cone speakers and can be used for paging systems (voice reproduction) as well as musical reproduction. Made of steel, with hanging lamp fixture finished in silver. Acts as infinite baffle, with response from 60 to 10,000 cycles. By Racon Electric Co., 52 East 19th St., New York, N. Y. RADIO SERVICE-DEALER.

### RADIO CITY

**Multitester**—The Model 414 Universal Deluxe Multitester is now available in four additional series.

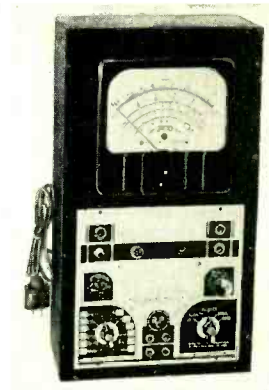

Series V7 has a 7 $\frac{1}{4}$ " bakelite square meter, with jewel indicating light, and front panel screw cap holder for immediate replacement of meter fuse. Series V9 is the same except that meter is the 9-inch round type.

In Series RP7 the panel is arranged horizontally for rack mounting and there is no overall case; otherwise it is similar to V7. RP9 is identical to RP7, but has the 9-inch round meter. By Radio City Products Co., 88 Park Place, New York, N. Y. RADIO SERVICE-DEALER.

### RCA

**P-A Amplifier**—Model MI-12214, for general p-a applications, has 50-watt output. Incorporates inverse feedback, and automatic bass compensation for record reproduction. Two mike and two phono input plugs are provided, the phono inputs being for magnetic and crystal pickups.



Frequency response is essentially flat between 50 and 10,000 cycles. Terminal board provides output impedances of 4, 7.5, 15, 60 and 250 ohms. By making certain indicated connections, additional impedances from .05 to 192 ohms may be provided. By RCA Manufacturing Co., Camden, N. J. RADIO SERVICE-DEALER.

### RSE

**Condenser Tester**—Designed to locate intermittently open and high-resistance bypass and coupling condensers of all types, indicating capacity value simultaneously. During test, a heavy r-f current at low voltage passes through condenser while 6E5 tube

## Trade Showings

### CLAROSTAT

**Power Resistor Decade Box**—Capable of handling real power so that it can be inserted in actual circuits to simulate working conditions. Has a range of from 1 to 999,999 ohms at a maximum of 1000 volts, by means of six decade switches. Each decade will dissipate 225 watts. The maximum current per decade is: No. 1, 5 amps.; No. 2, 1.5 amps.; No. 3, 0.5 amp.; No. 4, 0.15 amp.; No. 5, .05 amp.; No. 6, .005 amp.



The instrument measures 13" x 8½" x 5-¾", and weighs 11 pounds. By Clarostat Mfg. Co., Inc., 285 N. 6th St., Brooklyn, N. Y. RADIO SERVICE-DEALER.

### CORNELL-DUBILIER

**Capacitor Analyzer**—Model BF-50 all-purpose unit, providing measurements of capacity from 10 mmfd to 240 mfd, power factor from 0 to 50%, and insulation resistance to 1500 megohms.

A Wien Bridge arrangement insures permanent accuracy of measurements and independence of line-voltage variations. Balance is indicated by a visual eye with a 12A7 amplifier. Has built-in d-c power supply of approximately 450 volts for use

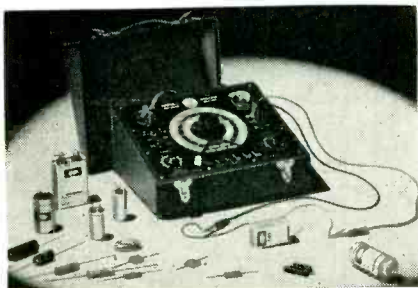

in leakage and insulation resistance measurements. By Cornell-Dubilier Electric Corp., South Plainfield, N. J. RADIO SERVICE-DEALER.

### DACO

**"Radiometer"**—A complete radio servicing laboratory in one compact instrument. Contains a vacuum-tube volt-ohm-milliammeter with 7-inch scale and a sensitivity of 3,000,000 ohms/volt on 3-volt range, and with ranges to 10,000 volts; an audio and supersonic oscillator with a range of 20 to 150,000 cycles; an i-f and r-f oscillator with a 50 kc to 100 mc range; a signal tracer of 5 bands and video amplifier, with selection for am, fm and television; a 2-inch oscilloscope with sweep generator



having a range of 10 to 25,000 cycles and sweep amplifier of internal 60-cycle calibrated voltage, and a p-m speaker.

The Radiometer is 32" high and 24" in width. By Dayton Acme Co., 2339 Gilbert Ave., Cincinnati, Ohio. RADIO SERVICE-DEALER.

### GENERAL CEMENT

**Chemical Kit**—Complete kit of chemical necessities for the serviceman, containing service cement, carbon-x, grapholine,



scratch polish, non-slip compound, dial oil, contact cleaner and dial drive cement. Each container has handy applicator.

Put up in leatherette pocket case by General Cement Mfg. Co., Rockford, Ill. RADIO SERVICE-DEALER.

### HALLICRAFTERS

**AM-FM Receiver**—Model S-27 with continuous coverage of 27 to 145 mc in three ranges, provides reception of both amplitude- and frequency-modulated signals. Fifteen tubes used.



Receiver has front-panel antenna trimmer, acorn tubes in r-f and converter cir-

cuits, voltage-regulated power supply, automatic noise limiter, plate-tuned oscillator, adjustable i-f bandwidth, meter for f-m tuning, push-pull a.f. with phase inversion and inverse feedback. By Hallcrafters, Inc., Chicago, Ill. RADIO SERVICE-DEALER.

### JENSEN

**Peri-Dynamic Projector**—Type S unit, employs heavy-duty p-m speaker with 15 to 25 watts power input capacity. The speaker is sealed within the inclosure and takes full advantage of the peri-dynamic principle. Result is sharp improvement in middle-frequency response and elimination of acoustic feedback trouble due to rear radiation.



Projector is weather-proof, heavily constructed of castings and sheet steel. Electrical access is by bayonet type plug and socket assembly. By Jensen Radio Mfg. Co., 6601 S. Laramie Ave., Chicago, Ill. RADIO SERVICE-DEALER.

### MEISSNER

**"Signal Splicer"**—A coupling system in which tubes are not used, to match the impedance of the antenna to the receiver, and resulting in a boost in signal strength, reduction of noise pick-up and an improve-

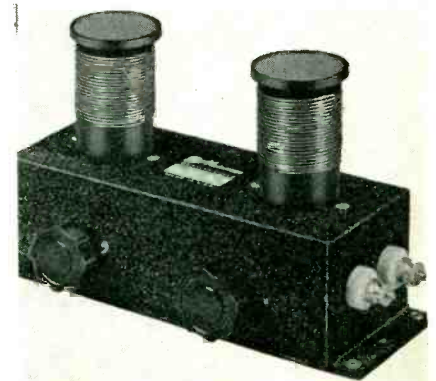

ment in image rejection. Coils provided cover the amateur bands. Other coils available. By Meissner Manufacturing Co., Mt. Carmel, Ill. RADIO SERVICE-DEALER.

### NATIONAL UNION

**Battery Tester**—Model 633, made by Triumph Mfg. Co. This is a direct tester with a switch setting proper voltages for battery

# Trade Showings

ALPHABETICALLY LISTED

## ABC RADIO LABS

**Short-Wave Converter**—Designed for use in conjunction with any auto radio for short-wave reception. Model 500-A has a range of 1600 to 6000 kc. Model 600-A covers a range of 5800 to 18,500 kc.

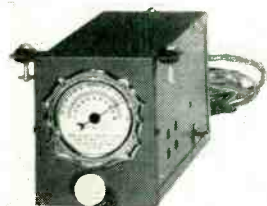

The Converters employ a 6KS mixer-oscillator and a 6J7 i-f amplifier. The i-f peak is adjustable from 600 to 700 kc. By ABC Radio Laboratories, 3334 N. New Jersey St., Indianapolis, Ind. RADIO SERVICE-DEALER.

## ADVANCE

**Midget Relay**—Measures 1½" x ¾". Un-grounded construction permits mounting on any type panel. Contact combinations are dpst and dpdt. Has ⅛" silver contacts to handle up to 200 watts on non-inductive a-c loads. Dependable service may be

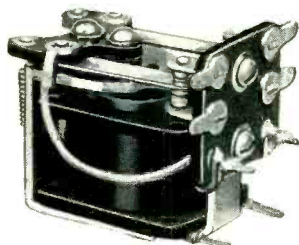

attained on as little as .10 watt, with safe continuous-duty rating of plus 2 watts without danger of over-heating. High d-c efficiency, hum-free a-c operation, wide range of coil voltages. By Advance Electric Co., 1260 W. 2nd St., Los Angeles, Calif. RADIO SERVICE-DEALER.

## AEROVOX

**Midget Electrolytics**—For applications calling for very high capacity values at very low voltages, seven popular values and



voltage ratings are now offered in the midget metal-can electrolytics by Aerovox Corporation of New Bedford, Mass. The capacities range from 1000 to 3000 mfd, with working voltages of 6, 12 and 15 d-c. The metal can is fully protected and insulated by the paper sleeve extending for the full length and rolled over the can edges, to preclude shorting of leads on the can. Units are supplied with mounting straps, except for a larger can size unit which has a standard mounting ring. RADIO SERVICE-DEALER.

## ATR

**Phono Inverters**—Midget units, in three models, invert 110 volts d.c. to 110 volts a.c., 60 cycles, at an output of 15 watts. Model PCP is for operation of small pho-

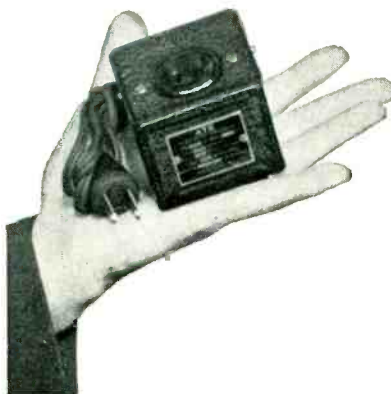

nograph motors and similar a-c devices. Model PCP-F has built-in r-f interference suppressor. Model PCP-R has input and output leads, rather than cord and receptacle, for installation inside phono-radio combinations.

Model PCP weighs less than one pound and measures 2-5/8" x 2-5/8" x 2-5/16". By American Television & Radio Co., 300 East 4th St., St. Paul, Minn. RADIO SERVICE-DEALER.

## ASTATIC

**Low-Pressure Pickups**—Models FP-18 and FP-38 are crystal pickups with permanent sapphire styli and a stylus pressure of 1 ounce. Torque wire coupling is employed between stylus and crystal, replacing the rubber coupling member ordinarily used.



Model FP-18, for use on commercial records, has a frequency range of 30 to 7000 cycles, and an open-circuit output voltage at 1000 cycles of 0.85 volt. Model FP-38, for high-fidelity applications, has a frequency range of 30 to 10,000 cycles and an output voltage of 0.65 volt.

Also available is Model FL-58, using replaceable needles, and having a needle pressure of 2 ounces. Frequency range is 30 to 6500 cycles, open-circuit output, 1.25 volts. By Astatic Microphone Laboratory, Inc., Youngstown, Ohio. RADIO SERVICE-DEALER.

## ATLAS

**Break-In Switch**—For all mikes or circuits having single conductor shielded cable connections. Model SW-1 offers on-off



or press-to-talk operation. Button is pressed for the latter, turned for the former. Can be instantly attached. All threads 5/8"-27 allowing use with "Hold-Tite" connectors and others. By Atlas Sound Corp., 1449 39th St., Brooklyn, N. Y. RADIO SERVICE-DEALER.

## CLARION

**71-Watt Amplifier**—Transformer Corporation of America, through the Clarion Institute of Sound Engineers, has announced the Model A-95, 71-watt super-power unit, having a peak wattage of over 100, facili-

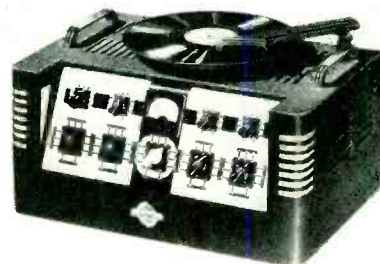

ties for 4 microphones, 2 phono inputs, all of which may be operated simultaneously. Maximum gain of microphone input 127 db, individual bass and treble equalizers, master gain control, special low distortion inverse feedback circuit, 4 beam-power tubes, remote control, impedance selector switch, optional db-meter or 2" monitor speaker, studio control panel and optional model with built-on phono table and pickup. RADIO SERVICE-DEALER.

# Shop Notes

## FADA MODELS P58, PL58

### Tube Substitution

In substituting a 70L7GT tube for a 70A7GT tube in these receivers, circuit changes are necessary, as shown in the accompanying diagrams.

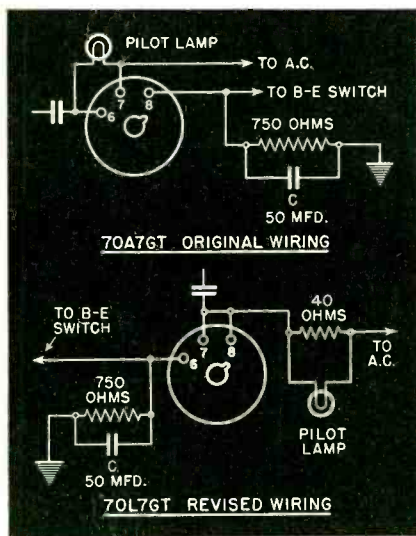

As noted, the pilot lamp lead is removed from pin No. 6 and moved to pin No. 8; the lead originally on pin No. 8 is moved to pin No. 6. Pins No. 7 and 8 are then wired together. A 40-ohm, 1-watt resistor and one pilot lamp lead are wired to pins 7 and 8. A tie is fastened to a convenient place on the chassis to anchor the other pilot lamp lead and shunt resistor.

The bypass condenser, *C*, 25 mfd in earlier models, has been replaced by a 50-mfd unit, as indicated.

## STROMBERG-CARLSON 400 Series Dial Pointer

In case the dial pointer in any of the 400 series receivers becomes bent during transportation or handling, so that it rubs either against the background of the dial or the glass, it is a simple matter to correct this without removing the chassis.

Simply adjust the pointer so that it is approximately in the middle of the dial and reach in from behind and lift the slide to which the pointer is attached until it is just off the slide bar. Then, holding the slide between thumb and first finger, bend it in the appropriate direction so that when it is replaced on the slide bar, the pointer will be in the proper operating position.

### F.M.-A.M. Antenna Connections

The correct methods for connecting various types of antennas to Stromberg-Carlson combination Amplitude- and Frequency-Modulation Receivers are shown in the accompanying drawings.

The drawing for the Stromberg-Carlson No. 6 Antenna System shows the red lead connected. The green lead may be connected in place of the red to eliminate interference between stations on the standard broadcast range.

## No. 470 Receivers

The engineering information given in the No. 370 data book may be used for the No. 470 receivers.

The aligning information, diagrams and general instructions are essentially the same.

A volume-control motor is installed in the 470-PF chassis and a remote-control unit is supplied with each receiver. An automatic record changer is used. Additional phonograph compensation has been added as shown in the accompanying diagram.

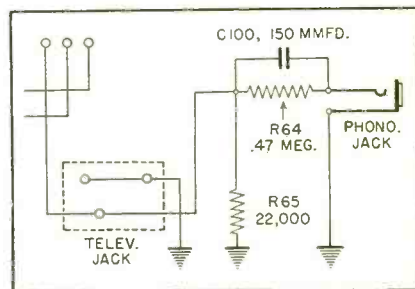

Compensation for Stromberg No. 470.

Set blocks—usually due to broken resistor in avc circuit of first detector.

### Chassis 5724 — 5725

Noisy tuning on automatic—Poor contact in speaker socket. Washer on latch bar grounding lug. Poor contact on band switch. Aeroplane lug on automatic grounding to No. 5 push rod. Automatic trimmer shorting.

Signal cuts out above 1400 kc—5 mega-cycle trimmer screwed in too tight.

Signal cuts out on local—distance switch—Defective 6A8 tube.

No change on treble button—Insulation of blue tone control lead cut by fastening lug.

Weak audio—Poor contact in television switch; open coupling condenser.

Oscillates—Open screen bypass; grid lead of 6K7 near avc lug or near plate lead 6A8; wave trap open or not properly adjusted.

### Phono Models

Insensitivity—check phono switch and plug contacts.

Weak phono—check shield on lead from crystal for poor ground.

### 1205 — 1503 Chassis

Improper action of volume control is usually caused by 6J5G in audio stage.

Poor radiorgan action is often caused by defective 6F8G in audio.

## ZENITH 1940 LINE

(Chassis 5417 to 5808; 1005 to 1503)

### General

Noisy when jarred—orange resistor on loop loading coil grounding against chassis.

Broken or loose leads in 6U5 socket.

Black wire on S.W. antenna coil not grounded properly to aeroplane terminal.

Noisy wavemagnet—rubber insulation of loop lead touching trimmer lug, antenna terminal, or other end of loop winding. Noise will be most noticeable at higher frequencies.

Poor connection to loop shields.

### Chassis 5808 — 1005 — 1103

Oscillates at 550 kc—improper adjustment of wave trap—too high resistance in plate circuit of 1232 tube.

Automatic dead or antenna trimmer won't peak—usually due to open winding on compensating coil.

Noisy tuning—Ground braid of gang rubbing against flywheel—Burrs on drive shaft shorting to volume control shaft.

Dial pulley rubbing against dial or chassis.

Tuning Indicator inoperative—resistor inside socket shorting to socket prong—loose lead in socket—cathode lug on voltage divider grounded by solder.

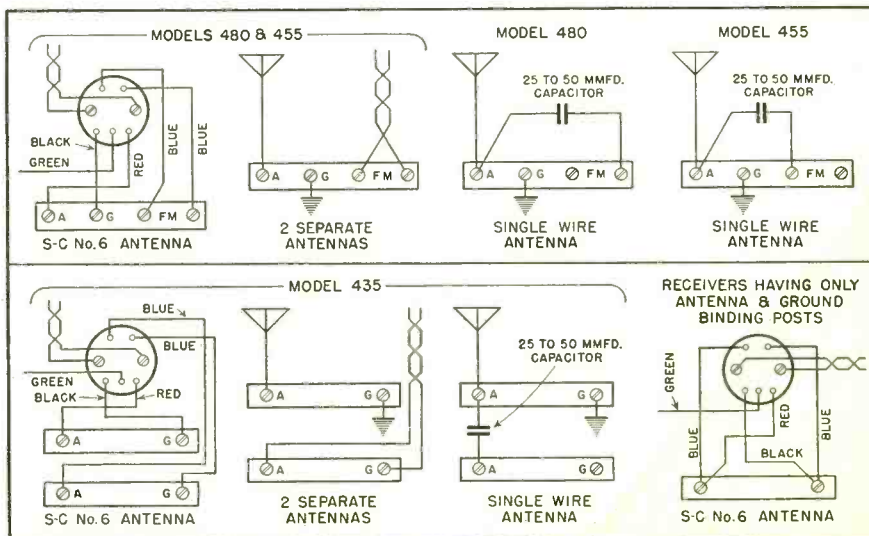

# TELEVOX

## JOBBER'S MAKE MONEY

*and so can you!*

### Mr. Jobber!

Here is the "Bank's Plan" which is clicking for every Jobber who has tried it. These Jobbers are making **TELEVOX Intercomm** the nucleus of their sound departments. They simply put a few **Demonstrators** at a time into their territories through their own salesmen with the cooperation of their service and sound men customers who bring in leads. These **demonstration** units easily sell themselves—and lead to additional recommendation sales. Everybody profits!

**TELEVOX Intercomm** systems are a staple item with a better than average net profit. They are easily demonstrated and sold because their advantages are so obvious to the user. Models do not change or become obsolete. Only a small initial investment can be turned over many times a year. There are no seasonal peaks or dips for intercomm sales.



**BANK'S TELEVOX** Systems assure you of high quality priced low enough to attract even the "price" buyers—at a good profit. Bank's Manufacturing Company is the oldest company in this field and is internationally known for its high standard of quality.



**BANK'S MANUFACTURING COMPANY**

5019-21 N. Winthrop Avenue, Chicago, Illinois, U. S. A.  
Licensed Under BANK Patent No. 1,922,415

### SERVICE DEALERS . . .

Intercomm selling is a profitable business

In every locality, large and small, there are logical customers for intercommunication equipment. Everywhere you turn, you will find factories, offices, hospitals, clubs, schools, depots, boats, restaurants, etc., that will buy intercomm systems once their practical use is demonstrated to them. Over 50,000 intercomm installations were sold last year by aggressive Jobbers and intercomm salesmen. Sales so far this year are ahead of last year. Are you getting your share?



### Mr. Service and Sound Man!

It's no longer necessary to grope for profits. Intercomm has proven itself a real source of income—from sales, installation fees and maintenance. All around you are thousands of potential customers—a ready market that's waiting to buy. **DEMONSTRATE** Televox Intercomm—show its advantages. It's so easy. Replace inoperative systems, too. Or—get demonstration leads for your Jobber. **YOUR JOBBER** will work with you on the demonstration and the sale. Share in the profit. And get installation and maintenance fees besides.

**The "Bank's Plan" Works!  
Send for Details Today.**

**Televox prices begin at \$39.95  
subject to regular trade discounts.**



# RAYTHEON

**MAKES**



**THEM ALL**

All the vast RAYTHEON engineering resources are exclusively devoted to anticipating fast moving radio circuit developments and pioneering in tube design to meet these developments *in advance*.

That is why there is a replacement RAYTHEON for every socket.

That is why thousands of the best businessmen in service work depend exclusively upon RAYTHEONS. That is why RAYTHEONS are used as standard

equipment in leading important receiving sets, auto radios, sound systems, coin operated phonographs, commercial communications receivers, amateur equipment and hearing aids.

The presence of RAYTHEONS is your guarantee that the equipment was engineered around the best of materials.

Your Raytheon Distributor has an unusual tube deal for you. See him without delay.

**WORLD'S LARGEST EXCLUSIVE RADIO TUBE MANUFACTURERS**

RAYTHEON PRODUCTION CORP. • New York • Chicago • Newton, Mass. • San Francisco • Atlanta